

Chiudiporta aerodinamico 564 Plus *Surface mounted door closer 564 Plus*

MAB

ASSA ABLOY

ASSA ABLOY, the global leader
in door opening solutions

NEW



Chiudiporta multiforza con fermo regolabile

Variable power door closer with adjustable Hold Open

Caratteristiche tecniche:

- Nuovo carter di finitura in ABS ad alta resistenza.
- Forza di chiusura variabile EN2 con braccio a slitta.
- Velocità di chiusura 180° - 10° circa, regolabile con valvola termostatica non critica.
- Unico corpo in ghisa per tutte le forze.
- Fermoporta integrato di facile e precisa regolazione.
- L'angolo di scatto è facilmente modulabile da un braccio a doppio tenditore fino alla sua eliminazione completa (chiusura dolce).
La possibilità di scatto potente anche da angolo ridotto a pochi gradi, garantisce la chiusura anche in caso di serrature con scrocci particolarmente duri.
- Ampia disponibilità di accessori per risolvere qualsiasi problema di montaggio.
- Finiture di serie: Argento EV1, Bronzo RAL7008, Oro RAL1004, Nero RAL9004, Bianco RAL9016. Altre finiture possono essere disponibili a richiesta.

Specifica per capitolati

Chiudiporta aerodinamico multiforza EN 2-5 (EN2 con braccio a slitta) con fermoporta regolabile integrato 70°-140°, termostatico, MAB 564 Plus.

Features:

- *New cover in special impact resistant ABS.*
- *Variable closing force sizes EN2 with sliding rail.*
- *Closing speed 180° - 10° adjustable by non critical thermostatic valve.*
- *One body size in high duty cast iron for all sizes.*
- *Integrated hold open device easily adjustable precisely to the desired angle.*
The possibility to ensure a powerful latch also from an arc of just a few degrees guarantees reduced noisy action in case of hard-to-latch locks.
- *Wide range of accessories to make all mountings possible.*
- *Standard finishes: Silver EV1, Bronze RAL7008, Gold RAL1004, Black RAL9004, White RAL9016. Other finishes may be available on request.*

Text for specifications

Variable power EN 2-5 (EN2 with sliding rail) surface mounted door closer with integrated adjustable hold open device 70°-140°, thermostatic, MAB 564 Plus.



Braccio standard / Link arm

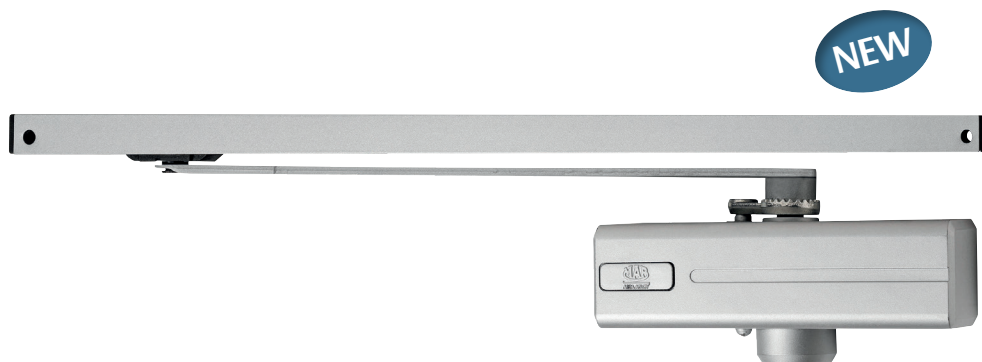

Braccio a slitta / Sliding rail arm

NEW

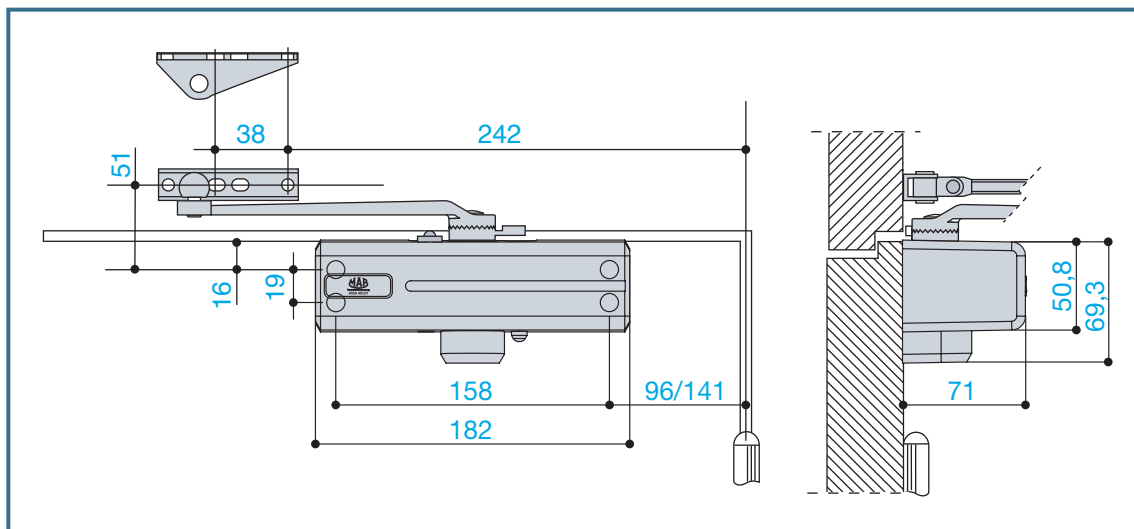

Come variare le forze How to set the closing force

La posizione di montaggio del corpo e il fissaggio del piedino determinano le forze 2-3-4-5.

The mounting location and the attachment shoe position determine the closing forces 2-3-4-5.

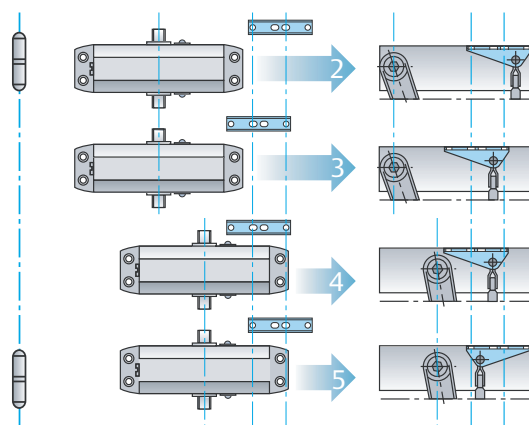

Dimensioni massime consigliate delle porte Recommended maximum doors sizes

In caso di porte soggette a vento o a correnti d'aria, selezionare la forza superiore.

In case of doors subject to wind or air draught, select the next higher size.

Norma europea EN 1154: momento di chiusura tra 0° e 4°
European standard EN 1154: closing moment between 0° and 4°

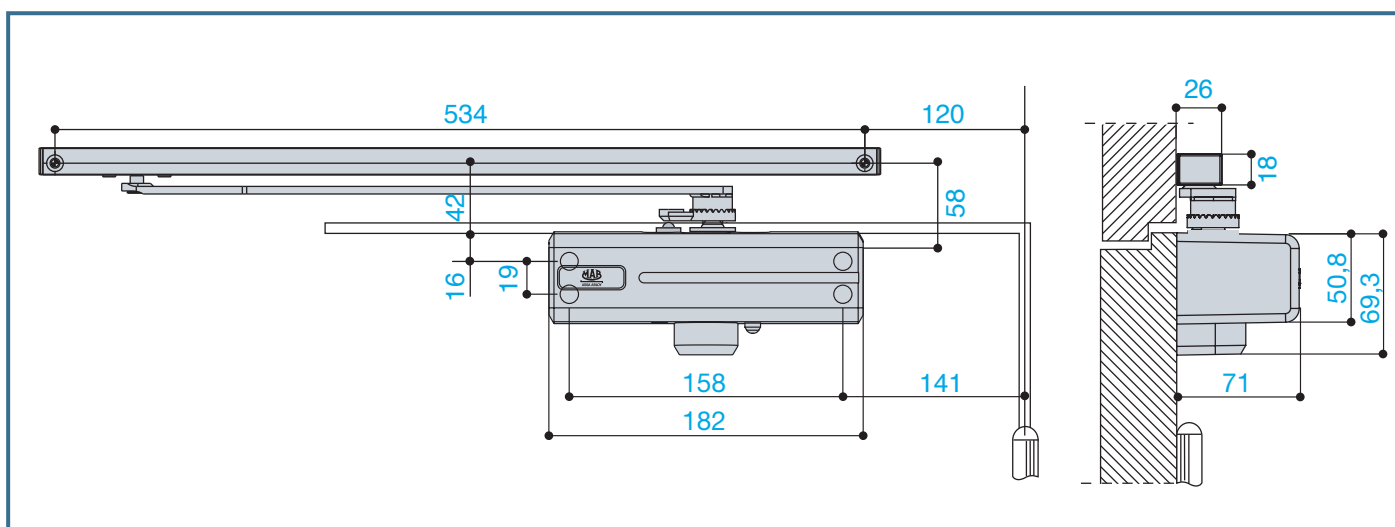
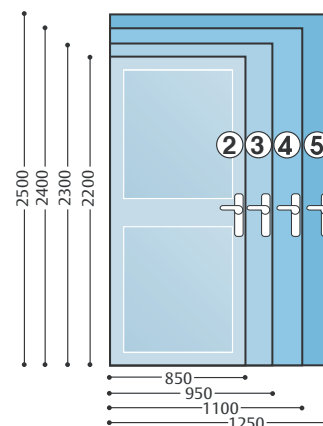



Regolazione della velocità di chiusura ($180^\circ - \sim 10^\circ$)
e dello scatto finale ($10^\circ - 0^\circ$)

*Closing speed ($180^\circ - \sim 10^\circ$) and latching speed
($10^\circ - 0^\circ$) adjustment*

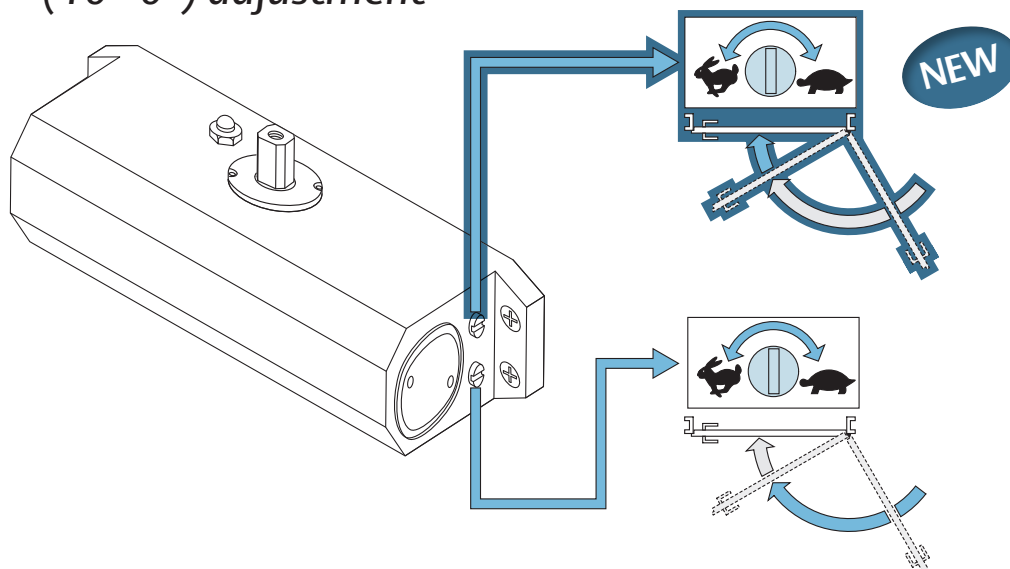

Regolazione dell'angolo di scatto finale ($\sim 10^\circ - 0^\circ$)

Adjustment of final latch angle ($\sim 10^\circ - 0^\circ$)

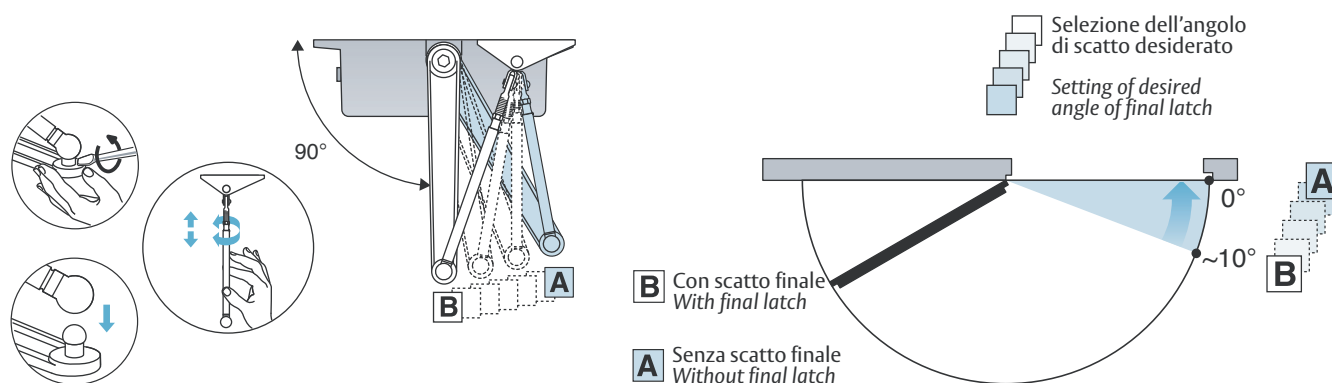

Fermaporta esclusivo MAB unico per braccio a compasso e slitta
*MAB unique adjustable hold open device suitable
for link arm and sliding rail.*

Il movimento solidale del braccetto e del pignone rende possibile una potente azione di fermo.
Per la sua efficacia è particolarmente indicato per porte ESTERNE.

*Being connected to the pinion, the shim ensures a strong hold open action between 70° and 140° .
Recommended for EXTERIOR doors.*

Braccetto fermaporta.
Hold open Shim.

Perno fermaporta.
Hold open Pin.

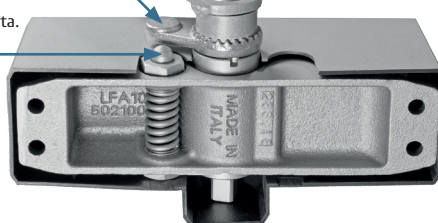

Forza / Force EN2

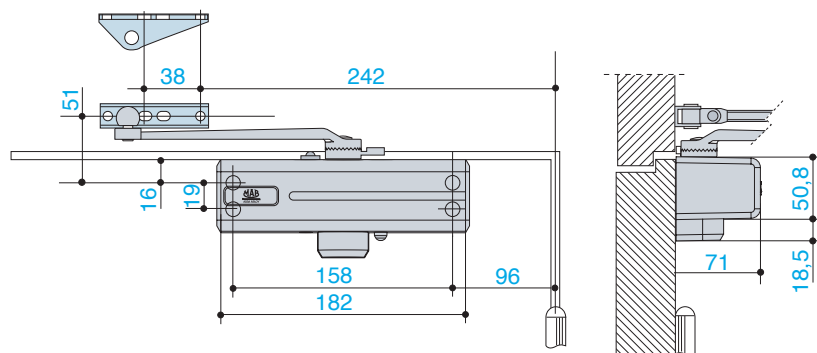

Forza / Force EN3

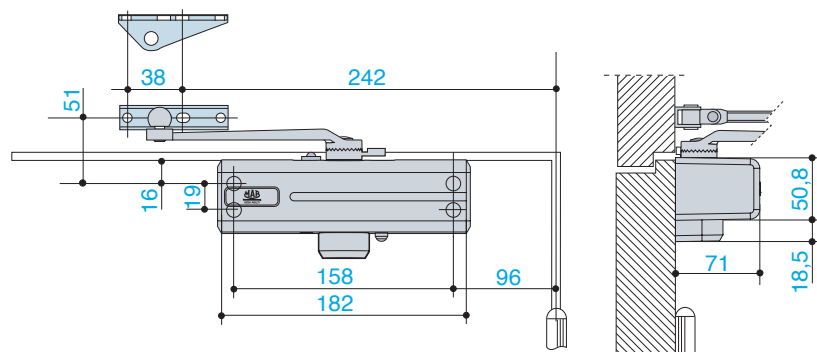

Forza / Force EN4

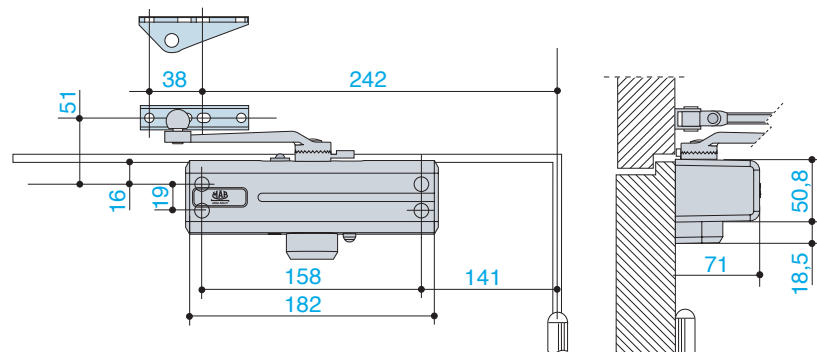

Forza / Force EN5

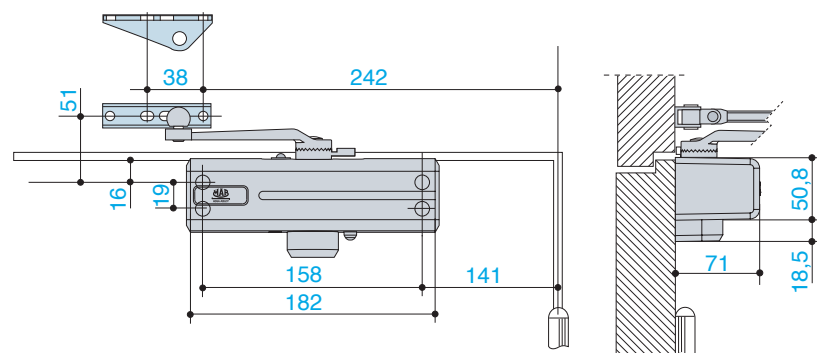

NEW

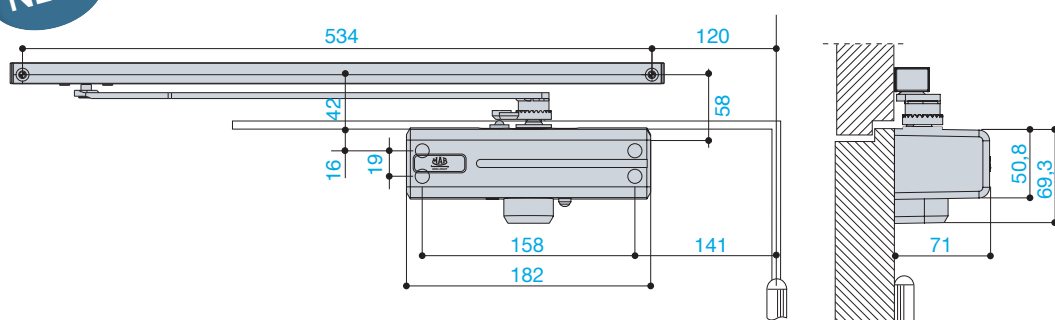

Montaggio normale lato cerniere *Standard mounting pull side (Hinge side)*

Forza / Force **EN2** **EN3** **EN4** **EN5**

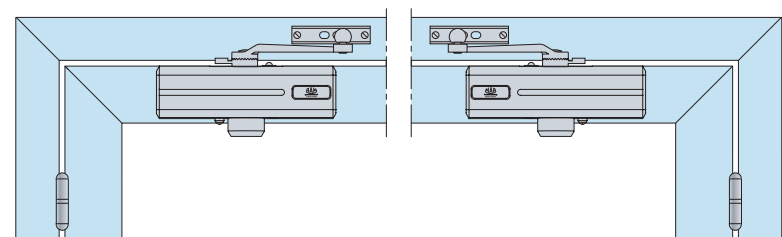

NEW

Forza / Force **EN2**

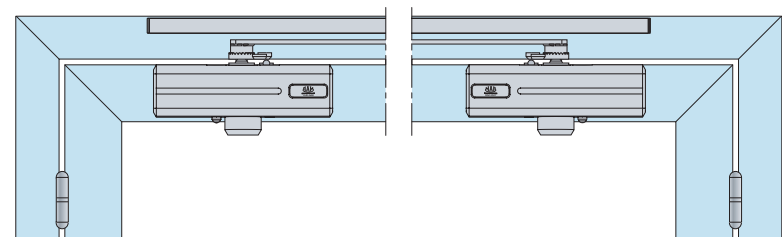

Montaggio rovesciato lato opposto cerniere *Reversed Mounting Push Side (No-hinge side)*

NOTA: Lo spessore della porta e l'interasse delle cerniere possono limitare l'angolo d'apertura e di inserimento fermaporta.
NOTE: Door thickness and off-set hinges may limit the opening angle and the hold open adjustability range.

Forza / Force **EN2** **EN3** **EN4** **EN5**

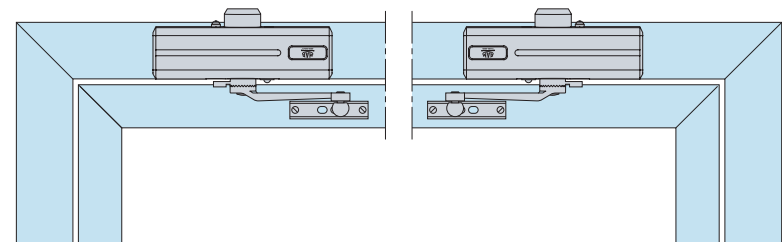

NEW

Forza / Force **EN2**

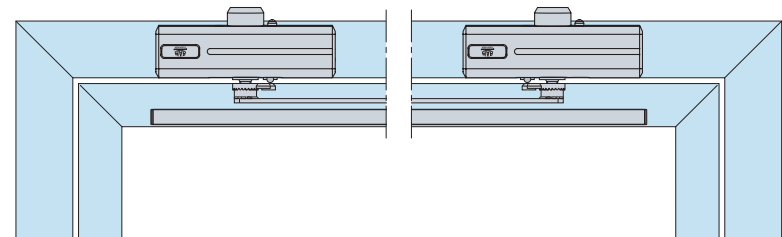

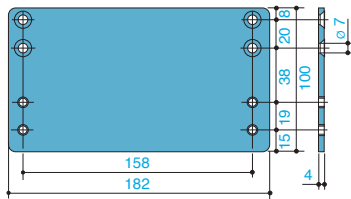

Piastra di abbassamento.
Drop plate.

Codice / Code

AC 56

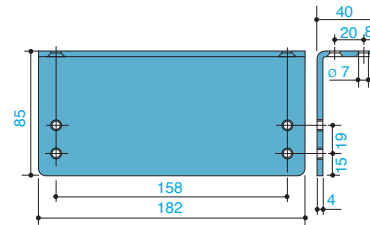

Piastra angolare.
Angle bracket.

Codice / Code

AC 55

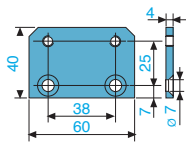
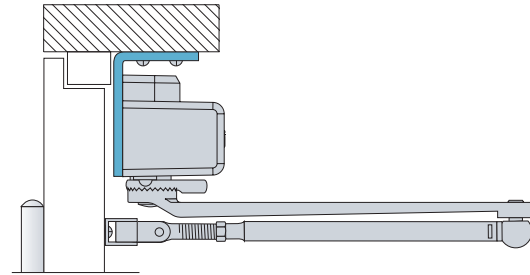
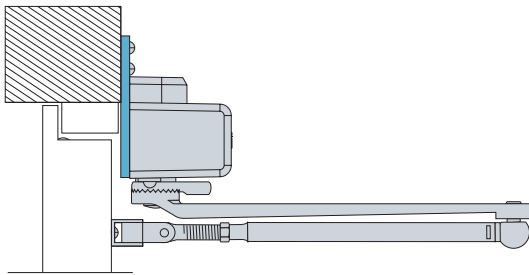

Piastrina d'innalzamento.
Shoe attachment plate.

Codice / Code

AC 566

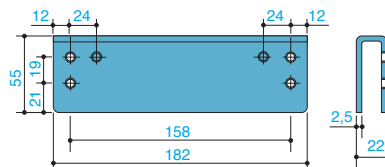

Cavaliere per montaggio
su porte in vetro temprato.
Clip-on plate for tempered
glass doors.

Codice / Code

AC 220

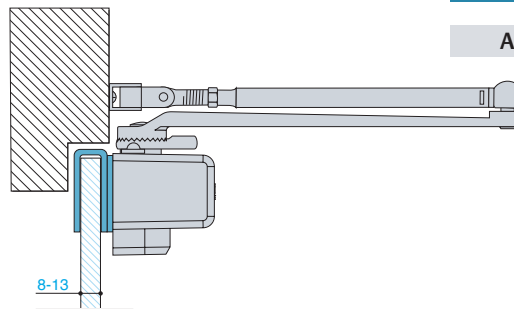
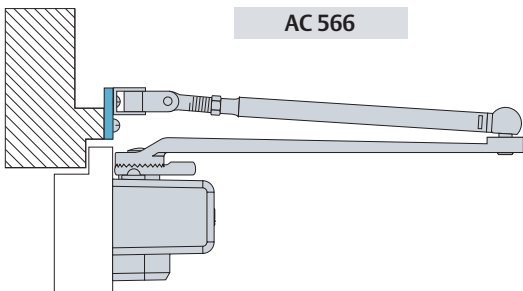

Braccio a slitta.
Sliding rail.

Codice / Code

G303

NEW

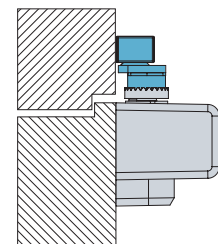
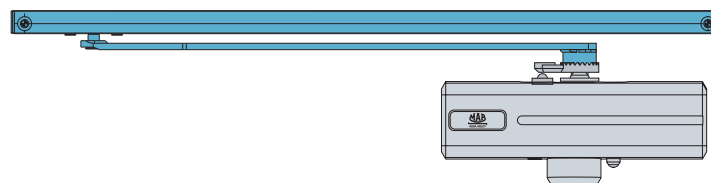



ASSA ABLOY Italia S.p.A.
Sede legale/Legal address:
Via Bovaresa 13 - 40017 San Giovanni in Persiceto (BO) Italy
Tel. +39 051 6812411 - Fax +39 051 827486
info@assaabloy.it - www.assaabloy.it

ASSA ABLOY is the
global leader in door
opening solutions,
dedicated to satisfying
end-user needs for
security, safety and
convenience.

www.assaabloy.com

