

BOSS 24V

SLAVE



Brevettato - Patent 0000267203



Operatore Opérateur Operator	Alimentazione Alimentation Power Supply	Lunghezza max leva basculante Max. longueur levier basculante Door lever's max. length	Superficie max basculante Max. surface basculante Max. door surface	Larghezza max basculante Max. largeur basculante Max. door width	Altezza max basculante Max. hauteur basculante Max. door height	Codice Code Code
BOSS 24V SLAVE IP44	230V ~ 50Hz	83 cm	12 m ² (1 BOSS MASTER + 1 BOSS SLAVE)	6 m per applicazione 2 motori pour application 2 moteurs for 2 motors application	2,5 m	AA40846
BOSS 24V SLAVE IP30						AA40846B



Scarica questo manuale sul tuo cellulare
Téléchargez ce manuel sur votre mobile
Download this manual on your mobile
Laden Sie dieses Handbuch auf Ihr Handy herunter
Descarga este manual en tu móvil



Disegni tecnici per progetti
Dessins techniques pour les projets
Technical drawings for projects
Technische Zeichnungen für Projekte
Dibujos técnicos para proyectos.

ATTENZIONE - PER LA SICUREZZA DELLE PERSONE È IMPORTANTE CHE VENGAANO SEGUITE TUTTE LE ISTRUZIONI CONSERVARE CON CURA QUESTE ISTRUZIONI

- 1° - Se non è previsto nel quadro elettrico, installare a monte del medesimo un'interruttore di tipo magnetotermico (onnipolare con apertura minima dei contatti pari a 3 mm) che riporti un marchio di conformità alle normative internazionali. Tale dispositivo deve essere protetto contro la richiusura accidentale (ad esempio installandolo entro quadro chiuso a chiave).
- 2° - Per la sezione ed il tipo dei cavi RIB consiglia di utilizzare un cavo di tipo H05RN-F con sezione minima di 1,5 mm² e comunque di attenersi alla norma IEC 364 e alle norme di installazione vigenti nel proprio Paese.
- 3° - Posizionamento di un'eventuale coppia di fotocellule: il raggio delle fotocellule deve essere ad un'altezza non superiore a 70 cm dal suolo e ad una distanza dal piano di movimento della **porta** non superiore a 20 cm. Il loro corretto funzionamento deve essere verificato a fine installazione in accordo al punto D.3.2 della EN 12453.
- 4° - Per il soddisfacimento dei limiti imposti dalla EN 12453, se la forza di picco supera il limite normativo di 400 N è necessario ricorrere alla rilevazione di presenza attiva sull'intera altezza della **porta** (fino a 2,5 m max). Le fotocellule in questo caso sono da applicare come indicato nella norma EN 12453 punto D.4.1.

N.B.: È obbligatoria la messa a terra dell'impianto

I dati descritti nel presente manuale sono puramente indicativi.

RIB si riserva di modificarli in qualsiasi momento.

Realizzare l'impianto in ottemperanza alle norme ed alle leggi vigenti.

**ISTRUZIONI IMPORTANTI DI SICUREZZA PER L'INSTALLAZIONE
ATTENZIONE - L'INSTALLAZIONE NON CORRETTA PUÒ CAUSARE GRAVI DANNI
SEGUIRE TUTTE LE ISTRUZIONI DI INSTALLAZIONE**

- 1° - **Questo libretto d'istruzioni è rivolto esclusivamente a del personale specializzato** che sia a conoscenza dei criteri costruttivi e dei dispositivi di protezione contro gli infortuni per i cancelli, le porte e i portoni motorizzati (attenersi alle norme e alle leggi vigenti).
- 2° - L'installatore dovrà rilasciare all'utente finale un libretto di istruzioni in accordo alla 12635.
- 3° - L'installatore dovrà applicare in prossimità dei comandi o della basculante delle etichette di attenzione sui pericoli da intrappolamento.
- 4° - Controllare spesso l'impianto, in particolare i cavi, le molle e i supporti per scoprire eventuali sbilanciamenti e segni di usura o danni. L'utente finale non deve azionare elettricamente la basculante se questa necessita di manutenzione o riparazione dal momento che un guasto all'installazione o una porta non correttamente bilanciata può provocare ferite.
- 5° - L'installatore prima di procedere con l'installazione deve prevedere l'analisi dei rischi della chiusura automatizzata finale e la messa in sicurezza dei punti pericolosi identificati (seguendo le norme EN 12453).
- 6° - L'installatore prima di installare il motore di movimentazione deve verificare che la basculante sia in buone condizioni meccaniche e che si apra e chiuda adeguatamente.
- 7° - L'installatore dovrà installare l'organo per l'attuazione del rilascio manuale ad un'altezza inferiore a 1,8 m.
- 8° - L'installatore dovrà rimuovere eventuali impedimenti al movimento motorizzato della basculante (es. chiavistelli, catenacci, serrature ecc.)
- 9° - L'installatore dovrà applicare in modo permanente le etichette che mettono in guardia contro lo schiacciamento in un punto molto visibile o in prossimità di eventuali comandi fissi.
- 10° - Il cablaggio dei vari componenti elettrici esterni all'operatore (ad esempio fotocellule, lampeggianti, ecc.) deve essere effettuato secondo la EN 60204-1.
- 11° - Tenete i comandi dell'automatismo (pulsantiera, telecomando etc.) fuori dalla portata dei bambini. I comandi devono essere posti ad un'altezza minima di 1,5 m dal suolo e fuori dal raggio d'azione delle parti mobili.
- 12° - Prima di eseguire qualsiasi operazione di installazione, regolazione, manutenzione dell'impianto, togliere la tensione agendo sull'apposito interruttore magnetotermico collegato a monte dello stesso.
- 13° - A fine installazione l'installatore dovrà assicurarsi che le parti della porta non ingombrino strade o marciapiedi pubblici.
- 14° - **A fine installazione l'installatore dovrà assicurarsi che il motore di movimentazione prevenga o blocchi il movimento di apertura quando la porta è caricata con una massa di 20 kg, fissata al centro del bordo inferiore della porta.**

LA DITTA RIB NON ACCETTA NESSUNA RESPONSABILITÀ per eventuali danni provocati dalla mancata osservanza nell'installazione delle norme di sicurezza e delle leggi attualmente in vigore.

**ATTENTION - POUR LA SECURITE DES PERSONNES, IL EST IMPORTANT DE SUIVRE TOUTES LES ISTRUCTIONS
CONSERVER SOIGNEUSEMENT CES ISTRUCTIONS**

- 1° - Si ce n'est pas prévu dans la centrale électrique, installer en amont de celle-ci un interrupteur de type magnétothermique [omnipolaire avec ouverture minimum des contacts de 3 mm] qui porte une marque de conformité aux normes internationales. Ce dispositif doit être protégé contre la re-fermeture accidentelle (par exemple en l'installant dans un tableau fermé à clé).
- 2° - En ce qui concerne la section et le type des câbles, RIB conseille d'utiliser un câble de type H05RN-F ayant une section minimum de 1,5 mm² et de toute façon, s'en tenir à la norme IEC 364 et aux normes d'installation en vigueur dans le propre pays.
- 3° - Positionnement d'un couple éventuel de photocellules: le rayon des photocellules doit se situer à une hauteur qui ne doit pas être supérieure à 70 cm du sol et à une distance du plan de mouvement de la **porte** qui ne doit pas être supérieure à 20 cm. Leur bon fonctionnement doit être vérifié en fin d'installation selon le point D.3.2 de la EN 12453.
- 4° - Pour satisfaire aux limites imposées par la EN 12453, si la force de pointe dépasse la limite de la norme de 400 N, il est nécessaire de recourir au relevé de présence active sur la hauteur totale de la **porte** (jusqu'à 2,5 m max). - Les photocellules, dans ce cas, doivent être appliquées selon le point D.4.1 de la EN 12453.

N.B.: La prise de terre est obligatoire sur l'installation.

Les données décrites dans ce manuel sont purement indicatives.

RIB se réserve le droit de les modifier à tout moment.

Réaliser l'installation en conformité aux normes et aux lois en vigueur.

**ISTRUZIONI IMPORTANTI DI SECURITE POUR L'INSTALLATION
ATTENTION - UNE INSTALLATION NON CORRECTE PEUT CAUSER DE GRAVES DOMMAGES
SUIVRE TOUTES LES ISTRUCTIONS D'INSTALLATION**

- 1° - Ce livret d'instructions est adressé exclusivement à un personnel spécialisé qui connaît les critères de construction et les dispositifs de protection contre les accidents concernant les portails, les portes et les portes cochères motorisés (s'en tenir aux normes et aux lois en vigueur).
- 2° - L'installateur devra délivrer à l'utilisateur final un livret d'instruction en accord à la EN 12635.
- 3° - L'installateur devra appliquer à proximité des commandes ou de la porte basculante, des étiquettes de mise en garde contre le danger d'être pris dans la fermeture.
- 4° - Souvent contrôler l'installation, en particulier les câbles, les ressorts et les supports pour découvrir d'éventuels déséquilibres et signes d'usure ou dommages. L'utilisateur final ne doit pas actionner électriquement la porte basculante si celle-ci a besoin d'entretien ou de réparation, à partir du moment où une panne à l'installation ou une porte mal équilibrée peut être cause de blessures.
- 5° - L'installateur avant de procéder à l'installation, doit prévoir l'analyse des risques de la fermeture automatisée finale et la mise en sécurité des points identifiés dangereux (en suivant la norme EN 12453).
- 6° - L'installateur, avant d'installer le moteur de mouvement, doit vérifier que la porte basculante soit en bonnes conditions mécaniques et qu'elle s'ouvre et se ferme correctement.
- 7° - L'installateur devra installer l'organe pour l'exécution de la relâche manuelle à une hauteur inférieure à 1,8 m.
- 8° - L'installateur devra retirer d'éventuels obstacles au mouvement motorisé de la porte basculante (ex. verrous, serrures, etc).
- 9° - L'installateur devra appliquer, de façon permanente, les étiquettes qui mettent en garde contre l'écrasement, dans un endroit bien visible ou à proximité de commandes fixes éventuelles.
- 10° - Le câblage des divers composants électriques externes à l'opérateur (par exemple photocellules, clignotants, etc) doit être effectué selon la EN 60204-1.
- 11° - Tenir les commandes de l'automatisme (tableau, télécommande, etc) hors de portée des enfants. Les commandes doivent être placées à une hauteur minimum de 1,5 m du sol et hors du rayon d'action des parties mobiles.
- 12° - Avant l'exécution de toute opération d'installation, de réglage, d'entretien de l'installation, couper le courant en agissant sur l'interrupteur magnétothermique à cet effet, branché en amont de l'installation.
- 13° - A la fin de l'installation, l'installateur devra s'assurer que les parties de la porte n'englobent pas la rue ou le trottoir public.
- 14° - **A la fin de l'installation, l'installateur devra s'assurer que le moteur de mouvement prévienne ou bloque le mouvement d'ouverture quand la porte est chargée avec une masse de 20 kg fixée au centre du bord inférieur de la porte.**

LA SOCIETE RIB N'ACCAPTE AUCUNE RESPONSABILITE pour d'éventuels dommages provoqués par la non-observation dans l'installation, des normes de sécurité et des lois actuellement en vigueur.

**ATTENTION - FOR THE SAFETY OF PEOPLE IT IS IMPORTANT TO FOLLOW ALL THE INSTRUCTIONS
KEEP THESE INSTRUCTIONS WITH CARE**

- 1° - If it is not forecast in the electric gearcase, install a switch of magnetothermic type upstream, (omni polar with minimum part of the contacts of 3mm) with a check of conformity to the international standards. Such device must be protected against the accidental lockup (for example by installing inside a locked board).
- 2° - For the section and the type of the cables RIB advises to use a cable of H05RN-F type with 1,5 sqmm minimum section and, however, to keep to the IEC 364 and installation standards in force in your country.
- 3° - Positioning of a possible couple of photoelectric cells: the radius of the photoelectric cells must be at a height of no more than 70 cm from the ground and at a distance not superior to 20 cm from the motion plane of the door. Their correct working must be verified at the end of the installation in accordance with point D.3.2 of the EN 12453.
- 4° - To fulfil the limits set by EN 12453, and in case the peak force exceeds the normative limit of 400 N it is necessary to have recourse to the active presence survey on the whole height of the door (up to max 2,5 m) - The photocells, in this case, must be applied in accordance with the point D.4.1 of the EN 12453.

N.B.: The earthing of the system is obligatory.

The data described in this handbook are purely a guide.

RIB reserves the right to change them in any moment.

Carry out the system in the respect of the standards and laws in force.

**IMPORTANT SAFETY INSTRUCTIONS FOR THE INSTALLATION
ATTENTION - THE INCORRECT INSTALLATION CAN CAUSE SERIOUS DAMAGES
FOLLOW ALL INSTALLATION INSTRUCTIONS**

- 1° - This handbook is exclusively addressed to the specialized personnel who knows the constructive criteria and the protection devices against the accidents for motorized gates, doors and main doors (follow the standards and the laws in force).
- 2° - The installer will have to issue a handbook to the final user in accordance with the 12635.
- 3° - The installer will have to put the tags warning against the entrapping dangers near the controls and the horizontally pivoted door.
- 4° - Check frequently the system, in particular cables, springs and supports to find out possible unbalances, wear signs or damages. The final user must not operate electrically the horizontally pivoted door if this needs maintenance or repair, since a failure in the installation or a non correctly balanced barrier can provoke wounds.
- 5° - Before proceeding with the installation, the installer must forecast the risks analysis of the final automatized closing and the safety of the identified dangerous points (Following the standards EN 12453).
- 6° - Before installing the motion motor, the installer must verify that the door is in good mechanical conditions and that it adequately opens and closes.
- 7° - The installer must install the member for the manual release at a height inferior to 1,8 m.
- 8° - The installer will have to remove possible impediments to the motorized motion of the door (eg. Door bolts, sliding bolts, door locks etc.)
- 9° - The installer will permanently have to put the tags warning against the deflection on a very visible point or near possible fixed controls.
- 10° - The wiring harness of the different electric components external to the operator (for example photoelectric cells, flashlights etc.) must be carried out according to the EN 60204-1.
- 11° - Keep the automatism controls (push-button panel, remote control etc.) out of the children way. The controls must be placed at a minimum height of 1,5 m from the ground and outside the range of the mobile parts.
- 12° - Before carrying out any installation, regulation or maintenance operation of the system, take off the voltage by operating on the special magnetothermic switch connected upstream.
- 13° - At the end of the installation, the installer will have to make sure that the parts of the door do not encumber streets or public sidewalks.
- 14° - **At the end of the installation, the installer will have to make sure that the motion motor prevents or blocks the opening motion when the door is loaded with a 20 kg weight, fixed in the middle of the inferior edge of the door.**

THE RIB COMPANY DOES NOT ACCEPT ANY RESPONSIBILITY for possible damages caused by the non observance during the installation of the safety standards and of the laws in force at present.



ITALIANO

RAEE - Informazione agli utilizzatori

Il simbolo del cassonetto barrato riportato sull'apparecchiatura o sulla sua confezione indica che il prodotto alla fine della propria vita utile deve essere raccolto separatamente dagli altri rifiuti. L'utente dovrà, pertanto, conferire l'apparecchiatura giunta a fine vita agli idonei centri comunali di raccolta differenziata dei rifiuti elettrotecnici ed elettronici. In alternativa alla gestione autonoma, è possibile consegnare gratuitamente l'apparecchiatura che si desidera smaltire al distributore, al momento dell'acquisto di una nuova apparecchiatura di tipo equivalente. Presso i distributori di prodotti elettronici con superficie di vendita di almeno 400 m² è inoltre possibile consegnare gratuitamente, senza obbligo di acquisto, i prodotti elettronici da smaltire con dimensioni inferiori a 25 cm. L'adeguata raccolta differenziata per l'avvio successivo dell'apparecchiatura dismessa al riciclaggio, al trattamento e allo smaltimento ambientalmente compatibile contribuisce ad evitare possibili effetti negativi sull'ambiente e sulla salute e favorisce il reimpiego e/o riciclo dei materiali di cui è composta l'apparecchiatura.

L'eliminazione dei materiali va fatta rispettando le norme vigenti. Non gettate il vostro apparecchio scartato, le pile o le batterie usate nei rifiuti domestici. Avete la responsabilità di restituire tutti i vostri rifiuti da apparecchiature elettriche o elettroniche lasciandoli in un punto di raccolta dedicato al loro riciclo.

FRANÇAIS

DEEE - Informations pour les utilisateurs

Le symbole du caisson barre, la ou il est reporté sur l'appareil ou l'emballage, indique que le produit en fin de vie doit être collecté séparément des autres déchets. Au terme de la durée de vie du produit, l'utilisateur devra se charger de le remettre à un centre de collecte séparée ou bien au revendeur lors de l'achat d'un nouveau produit. Il est possible de remettre gratuitement, sans obligation d'achat, les produits à éliminer de dimensions inférieures à 25 cm aux revendeurs dont la surface de vente est d'au moins 400 m². La collecte séparée appropriée pour l'envoi successif de l'appareil en fin de vie au recyclage, au traitement et à l'élimination dans le respect de l'environnement contribue à éviter les effets négatifs sur l'environnement et sur la santé et favorise le réemploi et/ou le recyclage des matériaux dont l'appareil est composé.

Éliminez les matériaux en respectant les normes en vigueur. Ne jetez ni les vieux appareils, ni les piles, ni les batteries usées avec les ordures domestiques. Vous devez confier tous vos déchets d'appareils électriques ou électroniques à un centre de collecte différenciée, préposé à leur recyclage.

ENGLISH

WEEE - Information for users

If the crossed-out bin symbol appears on the equipment or packaging, this means the product must not be included with other general waste at the end of its working life. The user must take the worn product to a sorted waste center, or return it to the retailer when purchasing a new one. Products for disposal can be consigned free of charge (without any new purchase obligation) to retailers with a sales area of at least 400 m², if they measure less than 25 cm. An efficient sorted waste collection for the environmentally friendly disposal of the used device, or its subsequent recycling, helps avoid the potential negative effects on the environment and people's health, and encourages the re-use and/or recycling of the construction materials.

Materials must be disposed of in accordance with the regulations in force. Do not throw away your discarded equipment or used batteries with household waste. You are responsible for taking all your waste electrical and electronic equipment to a suitable recycling centre.

CARATTERISTICHE TECNICHE / INSTALLAZIONE BOSS 24V SLAVE

Porte basculanti max 12 m²

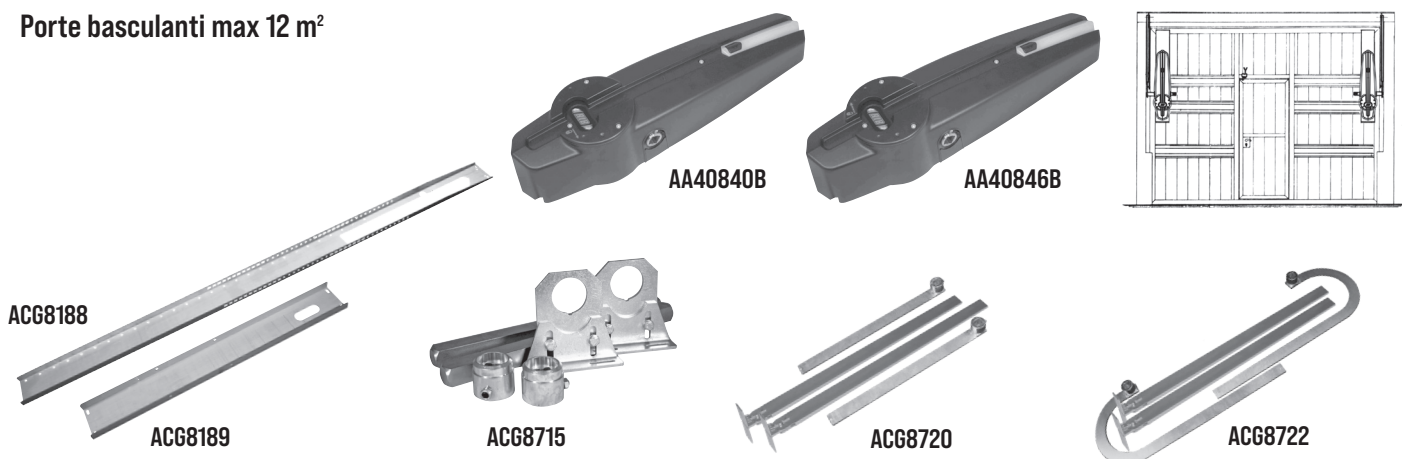

- n° 1 - AA40840B - BOSS 24V MASTER DX con finecorsa senza longherone
- n° 1 - AA40846B - BOSS 24V SLAVE SX senza longherone
- n° 2 - ACG8188 - Longherone L = 1,95 m per basculante non predisposta alla motorizzazione (o ACG8189 L = 0,8 m per basculante predisposta alla motorizzazione)
- n° 1 - ACG8715 - Rinvio laterale per 2 motori L = 30 cm
- n° 1 - ACG8720 - Coppia leve diritte (oppure ACG8722 - Coppia leve curve)

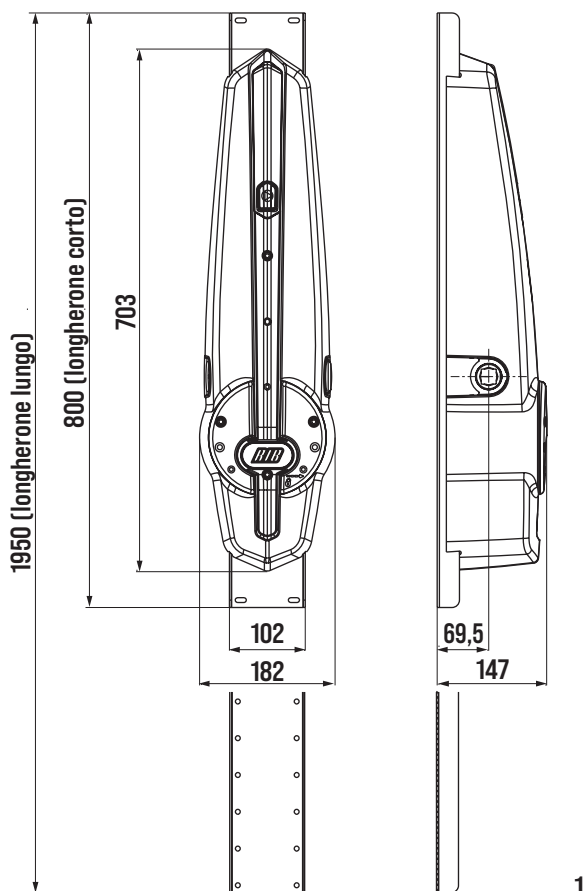

Misure in mm

CARATTERISTICHE TECNICHE

BOSS è un operatore irreversibile utilizzato per movimentare porte basculanti bilanciate a contrappesi.

È completo di un gruppo riduttore lubrificato con grasso sintetico, di uno sblocco manuale in mancanza di corrente e di un longherone **[opzionale]** per il fissaggio dell'operatore alla basculante.

La protezione IP44 di serie permette a BOSS di essere protetto da spruzzi d'acqua provenienti da tutte le direzioni.

BOSS 24V SLAVE, abbinato a BOSS 24V MASTER, è dotato di illuminatore a led, regolazione della velocità e sensore d'impatto in conformità alle Norme europee in vigore.

CARATTERISTICHE TECNICHE		BOSS 24V MASTER + BOSS 24V SLAVE
Lunghezza max leva basculante	cm	83
Superficie max basculante	m ²	12
Larghezza max basculante	m	6
Altezza max basculante	m	2,5
Coppia max 1 motore	Nm	350
Giri al minuto dell'operatore	rpm	1,8
Tempo di apertura regolabile	s	15 ÷ 23
Alimentazione di linea		230V ~ 50Hz
Alimentazione motore		24Vdc
Potenza 1 motore	W	55
Assorbimento linea di rete	A	1,2
Cicli normativi	n°	∞ - 20s/2s
Cicli giornalieri consigliati max	n°	36
Servizio		50%
Peso	kg	9,5 MASTER + 8 SLAVE
Rumorosità	db	<70
Temperatura di lavoro	°C	-10 ÷ +55 °C
Grado di protezione	IP	44

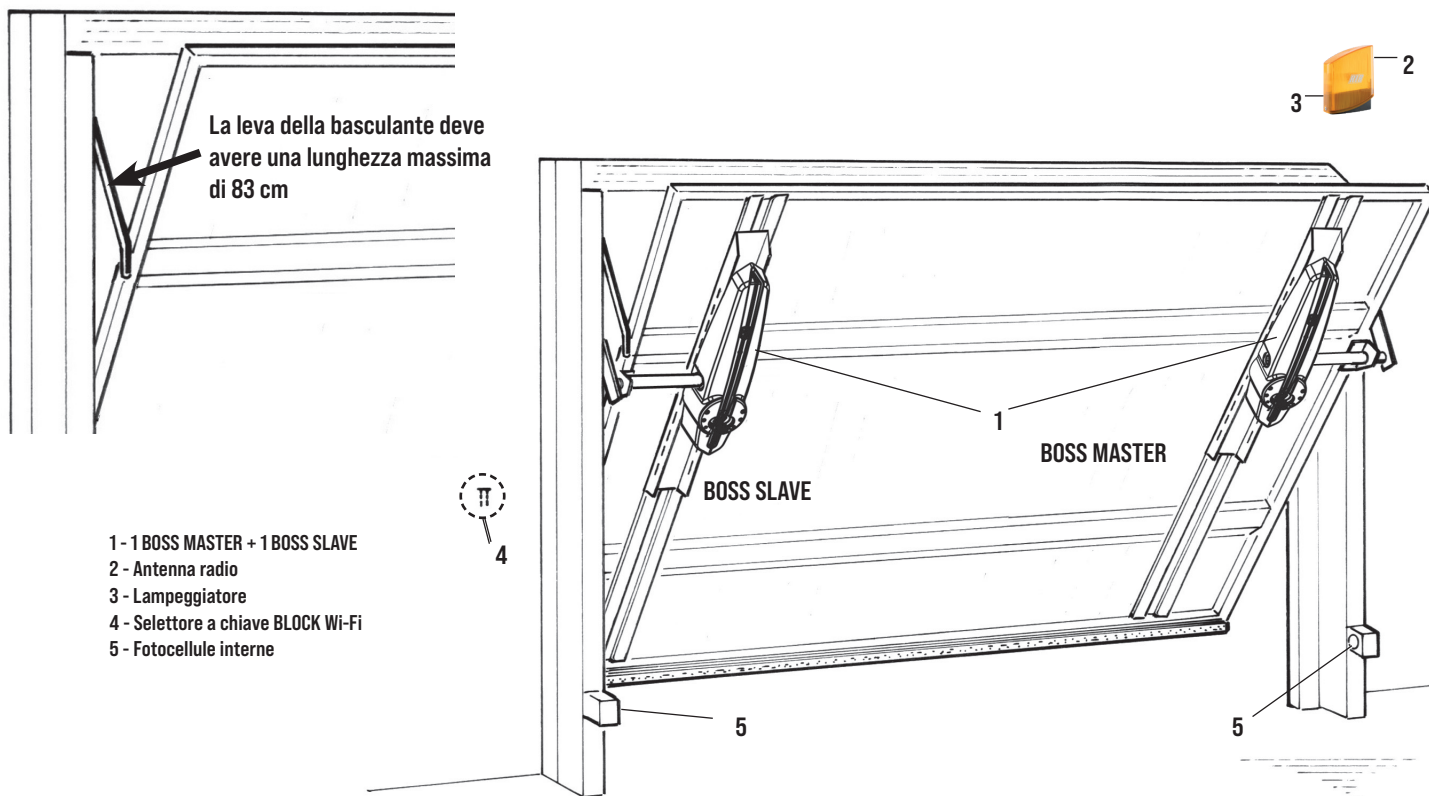

CONTROLLO PRE-INSTALLAZIONE

Per porte con larghezza fino a 6 m, altezza massima 2,5 m o comunque fino a 12 m² di superficie e leva della basculante con lunghezza massima 83 cm, si utilizzano 2 BOSS (MASTER AA40840 + SLAVE AA40845) montati come mostra la Fig. 3, una COPPIA DI LEVE DIRITTE cod. AC68720 (o una COPPIA DI LEVE CURVE cod. AC68722), il RINVIO LATERALE per 2 motori cod. AC68715 e 2 cod. AC68189 LONGHERONI CORTI o 2 cod. AC68188 LONGHERONI LUNGHI.

- Verificare che lo spazio compreso tra il telaio mobile della porta e i cassonetti che contengono i contrappesi sia superiore a 15 mm. In questo caso è possibile montare le LEVE DIRITTE. Se tale distanza risulta essere inferiore a 15 mm, utilizzare le LEVE CURVE rispettando le quote di montaggio descritte in Fig. 4.
- Verificare che i cuscinetti di scorrimento della porta basculante non siano bloccati e che le funi di fissaggio dei contrappesi siano in buono stato.
- Togliere, se esistente, la leva di chiusura manuale collegata alla serratura.

N.B. È obbligatorio uniformare le caratteristiche della basculante alle norme e leggi vigenti. La basculante può essere automatizzata solo se in buono stato e se rispondente alla norma EN 12604.

Non bisogna generare punti di intrappolamento (ad esempio tra basculante aperta e parete).

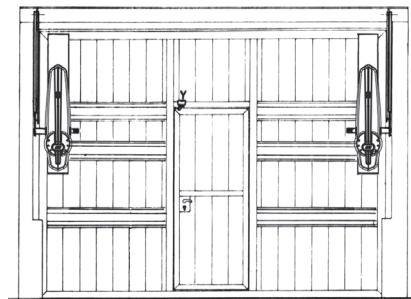

3

Componenti da installare secondo la norma EN 12453			
TIPO DI COMANDO	USO DELLA CHIUSURA		
	Persone esperte (fuori da area pubblica*)	Persone esperte (area pubblica)	Persone non esperte
mantenuto	A	B	non possibile
impulsivo - in vista (es. pulsante)	C o E	C o E	C e D, o E
impulsivo - non in vista (es. telecomando)	C o E	C e D, o E	C e D, o E
automatico	C e D, o E	C e D, o E	C e D, o E

* esempio tipico sono le chiusure che non accedono alla pubblica via.
 A: Comando ad azione mantenuta, tramite Pulsantiera es: cod. AC62013
 B: Comando ad azione mantenuta, tramite Selettore a chiave es: cod. ACG1010
 C: Regolazione della forza del motore o fotocellule per rispettare forze d'impatto come indicato in Annex A
 D: Coste e/o altri dispositivi supplementari per ridurre la probabilità di contatto con la porta.
 E: Dispositivi installati in modo tale che una persona non possa essere toccata dalla porta.

MONTAGGIO DI 2 BOSS PER PORTE FINO A 12 m²

APPLICAZIONE LEVE

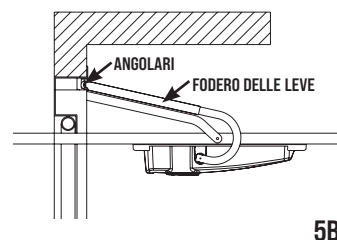
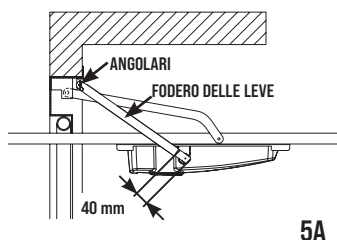
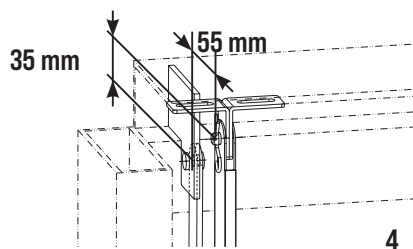

MONTAGGIO DELLA COPPIA LEVE DIRITTE (cod. AC68720) TRA MOTORE E TELAIO SUPERIORE DELLA PORTA

N.B.: La COPPIA LEVE DIRITTE TELESCOPICHE si può montare quando tra la parte mobile della porta e il cassonetto che contiene il contrappeso esiste uno spazio minimo di 15 mm.

- Con rivetti o viti si dovranno fissare gli angolari al telaio superiore rispettando le misure presenti in Fig. 4: se alla quota 35 mm, si trova la piastra di rinforzo del telaio della basculante, e' possibile fissare le staffe direttamente sopra alla piastra anche se la quota non potrà essere rispettata.

Nel caso la basculante sia già predisposta per la motorizzazione utilizzare gli appositi agganci. **Non utilizzare gli angolari forniti.**

- Inserire i foderi delle leve negli angolari e fissare con gli appositi perni e copiglie (Fig. 4).
- Prestare attenzione affinché una volta montati i foderi non urtino contro le leve di movimento della basculante.

MONTAGGIO DELLA COPPIA LEVE CURVE (cod. AC68722) TRA MOTORE E TELAIO SUPERIORE DELLA PORTA

N.B.: La COPPIA LEVE CURVE TELESCOPICHE è necessaria quando lo spazio compreso tra il telaio mobile della porta e i cassonetti che contengono i contrappesi è meno di 15 mm.

- Nel caso la basculante sia già predisposta per la motorizzazione utilizzare gli appositi agganci. **Non utilizzare gli angolari forniti.**

- Inserire i foderi delle leve negli angolari e fissare con gli appositi perni e copiglie (Fig. 4).
- Prestare attenzione affinché una volta montati i foderi non urtino contro le leve di movimento della basculante.

N.B.: La lunghezza del fodero e delle leve va modificata a seconda dell'altezza della basculante. E' necessario quindi accorciare sia il fodero che la leva in maniera che a porta aperta il fodero disti 40 mm dal centro del perno di traino e la leva non urti contro il perno di rotazione posizionato sugli angolari (Fig. 5A)

APPLICAZIONE LONGHERONE LUNGO (PER BASCULANTI NON PREDISPOSTE ALLA MOTORIZZAZIONE)

Cod. AC68188

Posizionare il longherone tenendo la parte superiore (asola passaggio cavi elettrici) rivolta verso l'alto (Fig. 6).

Fissare il longherone a filo con la parte mobile superiore della porta basculante distante 17 cm dal filo interno del fodero utilizzando per il fissaggio le viti autofilettanti 6,3x13 non in dotazione.

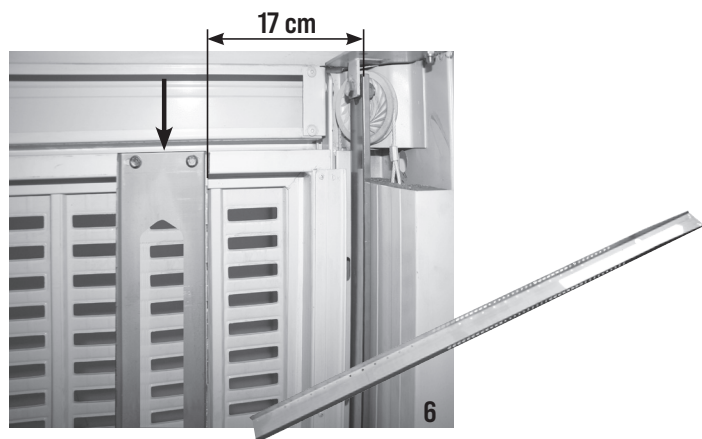

APPLICAZIONE LONGHERONE CORTO (PER BASCULANTI PREDISPOSTE ALLA MOTORIZZAZIONE)

Cod. AC68189

Calcolate la quota $L = C - 410$ [mm] a cui deve essere fissato verticalmente il longherone (Fig. 7-8).

Posizionarlo sugli appositi rinforzi verticali tenendo la parte superiore (asola passaggio cavi elettrici) rivolta verso l'alto in posizione verticale.

Fissare poi il longherone distante 17 cm dal filo interno del fodero utilizzando le 4 asole passanti con 4 viti metriche M6x25 e dadi autobloccanti non in dotazione.

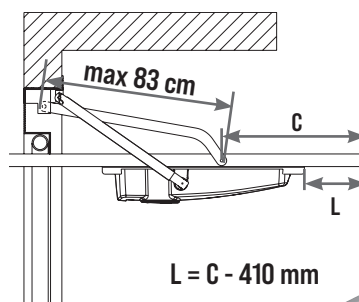

$$L = C - 410 \text{ mm}$$

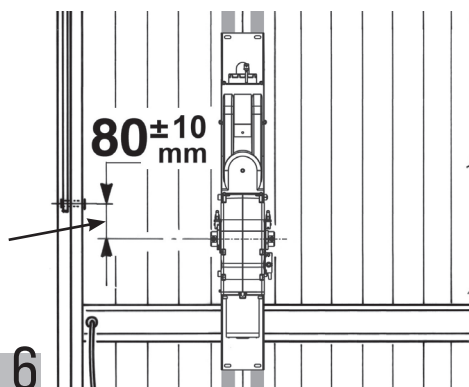

A montaggio ultimato, sia con LONGHERONE LUNGO che con LONGHERONE CORTO, l'asse dell'albero di uscita del riduttore dovrà essere posizionato ad una distanza di 80 ± 10 mm dall'asse del perno del braccetto della porta basculante.

MONTAGGIO DEGLI OPERATORI

- Fissare BOSS al longherone con le viti in dotazione (Fig. 9-10-11-12).
- Verificare il bilanciamento della porta basculante.
Se non corretto, in caso di porta non predisposta alla motorizzazione, aggiungere 9 kg a ciascun contrappeso per ottenere il corretto bilanciamento.

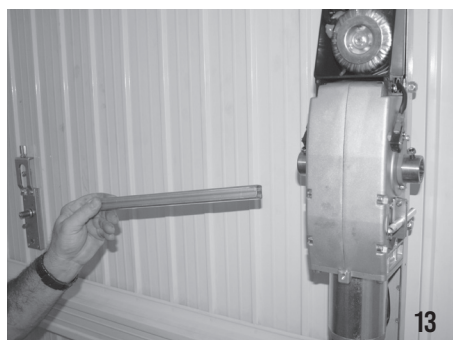
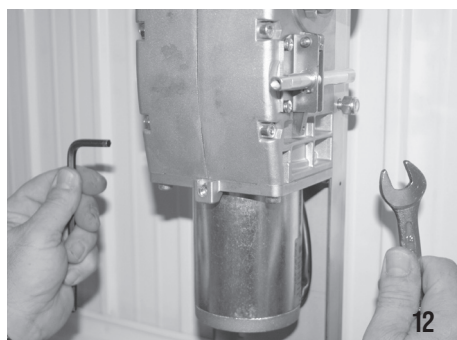
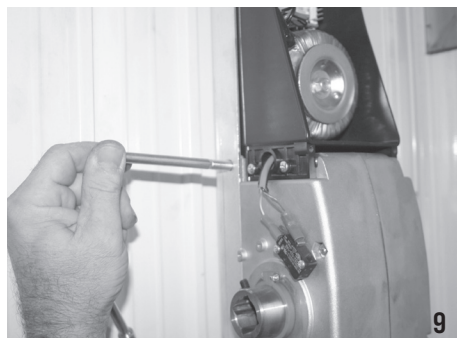

INSERIMENTO DELL' ALBERO QUADRO DI TRASMISSIONE NEGLI OPERATORI

- Introdurre l'albero quadro di trasmissione nell'albero di uscita dell'operatore (Fig. 13)

RIBILANCIAMENTO BASCULANTE

Applicando 2 motori BOSS alla basculante i suoi contrappesi devono essere appesantiti di ulteriori 9 kg per parte.

MONTAGGIO DI 2 BOSS PER PORTE FINO A 12 m²

FISSAGGIO GRUPPO RINVIO LATERALE 2 MOTORI

- Inserire le boccole con i grani sull'albero quadro 20x20 (Fig. 14).
- Fissare gli angolari di supporto regolabili al telaio mobile della porta basculante in asse con l'albero quadro (Fig. 15). **ATTENZIONE: viti di fissaggio non in dotazione.**
- Inserire le boccole nei supporti (Fig. 16) tirando i relativi bulloni (Fig. 17).
- Controllare che le LEVE DIRITTE (cod. ACG8720) siano perfettamente perpendicolari e non urtino i cassonetti dei contrappesi o la parte mobile della porta. Se lo spazio compreso tra il telaio mobile della porta e i cassonetti che contengono i contrappesi è meno di 15 mm, si dovrà usare la COPPIA LEVE CURVE (cod. ACG8722) (sempre rispettando le misure di Fig. 4).

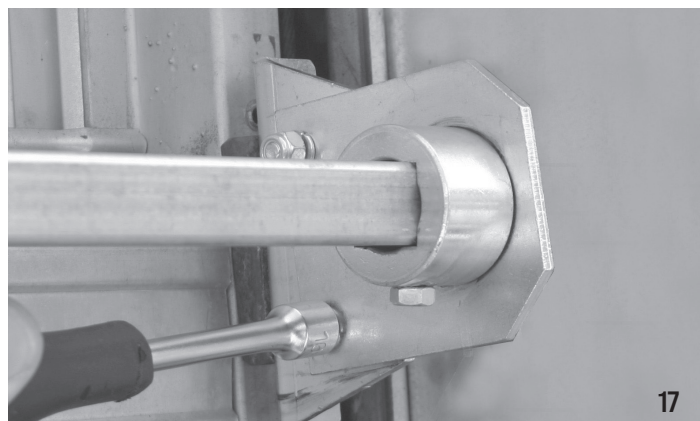
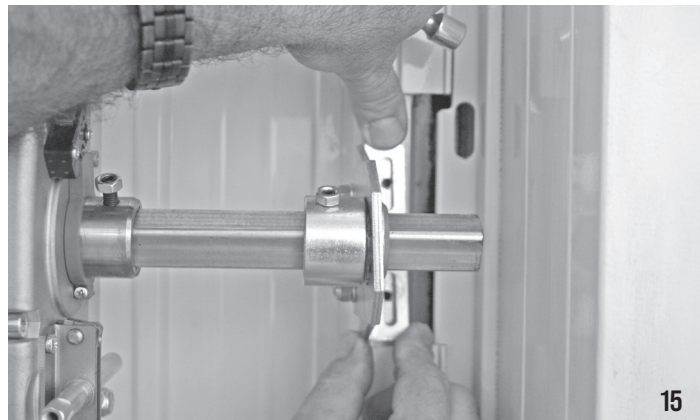
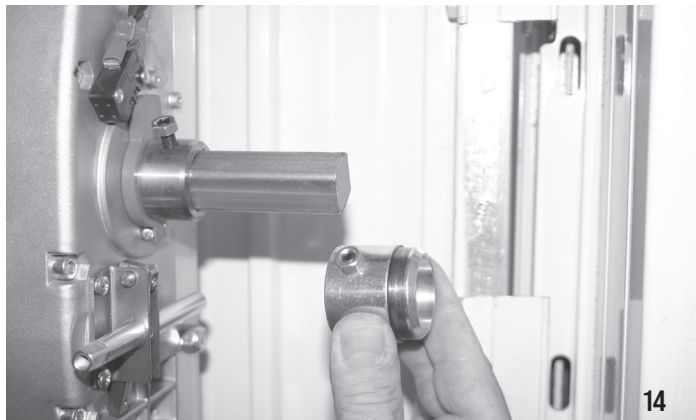

FISSAGGIO TUBOLARE E LEVE DI RINVIO LATERALE

- Infilare la leva nel fodero e introdurre la boccola saldata sull'albero quadro (Fig. 18).
- Iniziare a bloccare i grani situati sull'albero di traino (Fig. 19-20) sulle boccole di centraggio e i loro relativi controdati (Fig. 21).
- Fissare poi con il grano ed il controdatato le leve al tubolare (Fig. 22-23).
- Sbloccare meccanicamente gli operatori utilizzando la manopola in dotazione inserita nei relativi perni di sblocco (Fig. 24-25).
- Verificare il corretto movimento, poi ribloccare gli operatori.
- Lubrificare con grasso le leve e le guide della basculante.

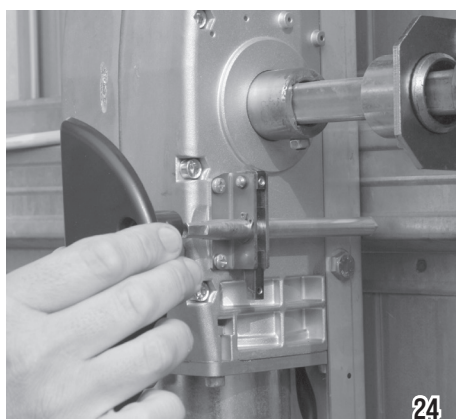
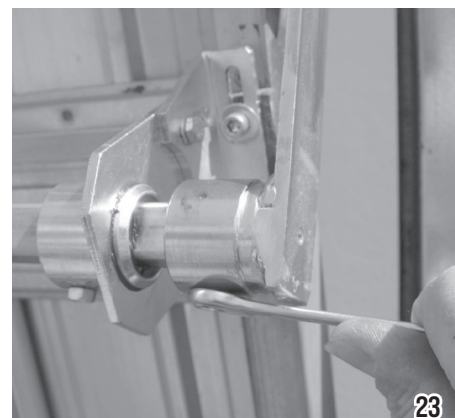
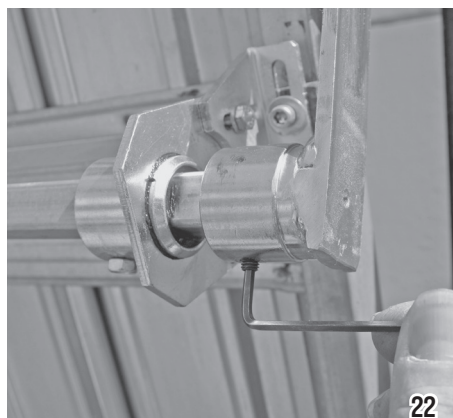
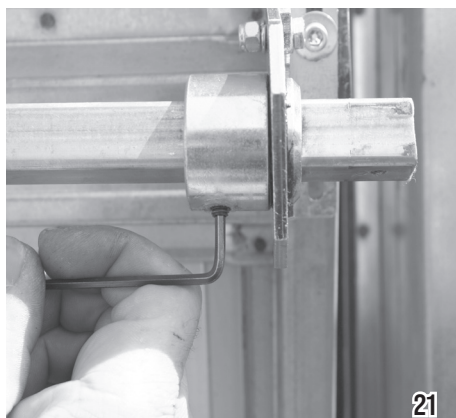
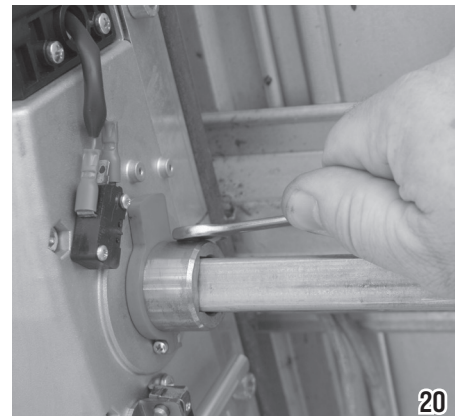
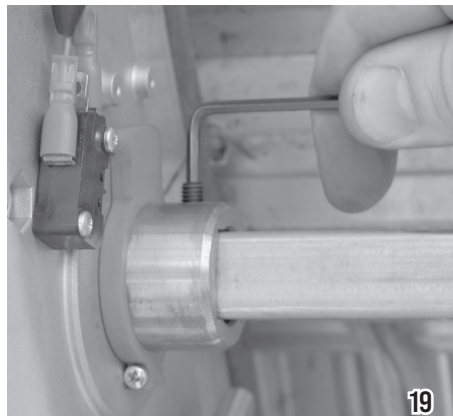

COLLEGAMENTO ELETTRICO

Dopo aver tolto il coperchio dal contenitore del quadro elettrico sia sul riduttore MASTER che SLAVE (Fig. 26) inserire la scheda SLAVE sulla scheda a bordo del riduttore MASTER (Fig. 30-31) incastrando il distanziale nell'apposito foro (Fig. 30). Eseguire il collegamento elettrico come da Fig. 69 per potere comandare a uomo presente la basculante.

ATTENZIONE: per garantire IPX4 è necessario montare i passacavi in gomma, presenti all'interno del quadro elettronico, negli appositi fori sul contenitore (Fig. 27) e montare la guarnizione tonda a filo aperto sul coperchio di chiusura (Fig. 28).

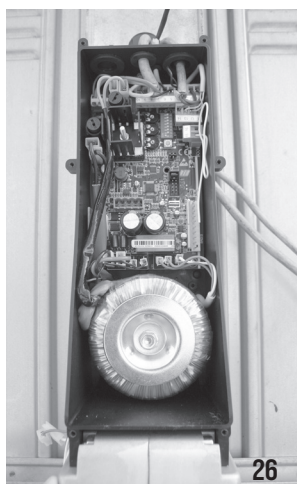

26

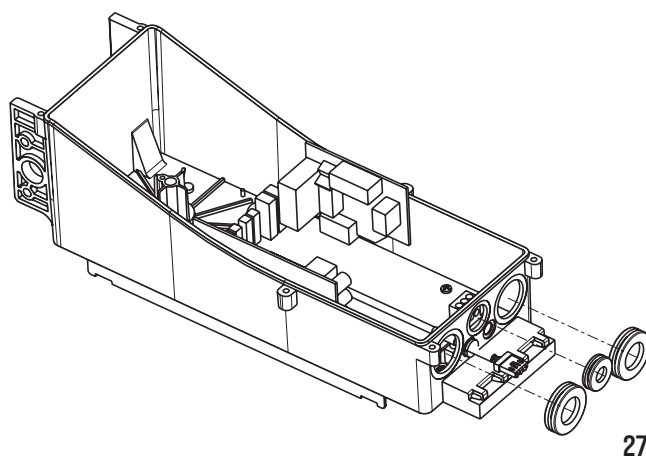

27

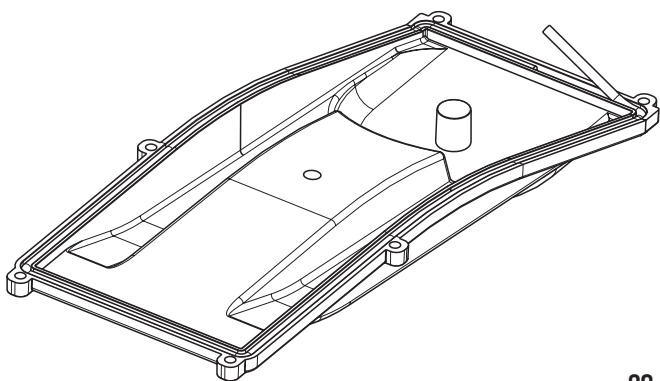

28

FISSAGGIO CAVO ELETTRICO LATO OPERATORE MASTER

Il cavo elettrico che alimenta l'operatore NON deve essere fissato alla leva telescopica (Fig. 29).

Il cavo dovrà formare una curva in modo che durante il movimento della porta non sia soggetto a tensioni o strappi.

È consigliabile proteggere il cavo all'uscita del foro della lamiera della porta con una guaina per evitarne il taglio durante il movimento.

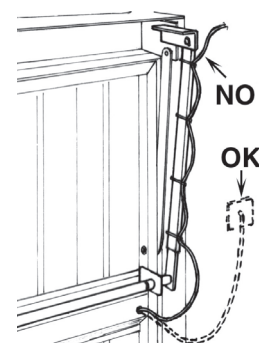

29

REGOLAZIONE FINECORSA SU OPERATORE MASTER

- Posizionare DIP 8 su ON e premere il tasto presente nel quadro elettronico (Fig. 31) per aprire la basculante. Rilasciare il pulsante una volta completata l'apertura. Allentare la vite di tenuta della camme verde e ruotarla fino a fare scattare il microinterruttore (Fig. 34).
- Serrare la vite di tenuta della camme verde (Fig. 35).
- Premere il tasto presente nel quadro elettronico (Fig. 31) per chiudere la basculante. Rilasciare il pulsante una volta completata la chiusura. Allentare la vite di tenuta della camme rossa e ruotarla fino a fare scattare il microinterruttore (Fig. 37).
- Serrare la vite di tenuta della camme rossa (Fig. 38).
- Eseguire un ciclo completo di apertura e chiusura per verificare il perfetto posizionamento delle camme. In caso di necessità correggere la posizione.
- Posizionare DIP8 su OFF.

Per il collegamento degli accessori e le funzionalità del quadro vedere il capitolo COLLEGAMENTI ELETTRICI.

Chiudere con l'apposito coperchio la scatola elettrica utilizzando le 6 viti in dotazione.

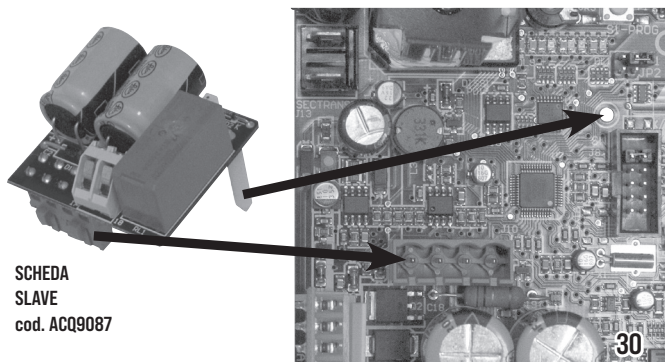

30

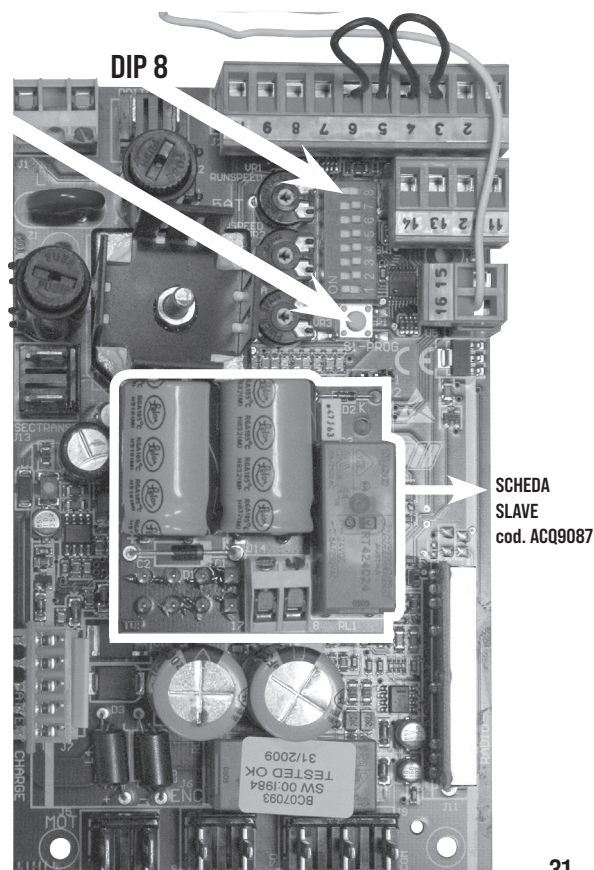

31

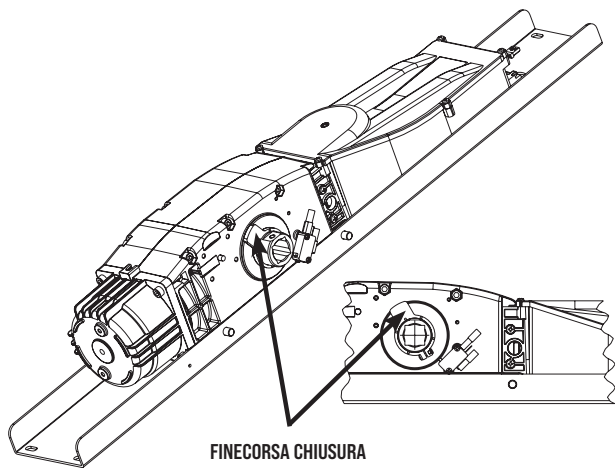

**FINECORSO CHIUSURA
CAMME ROSSA**

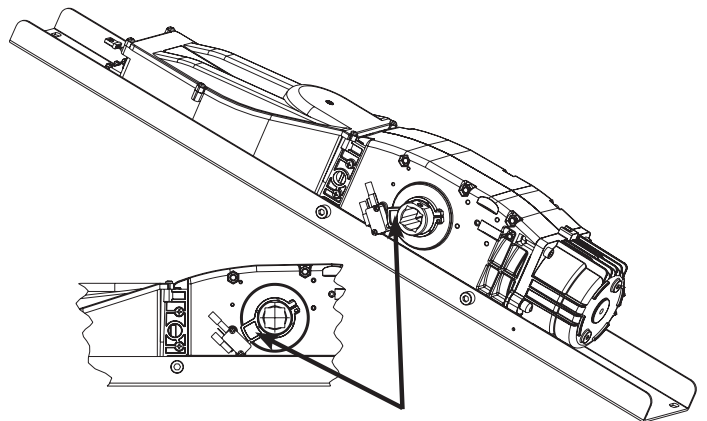

**FINECORSO APERTURA
CAMME VERDE**

32

REGOLAZIONE FINECORSO APERTURA

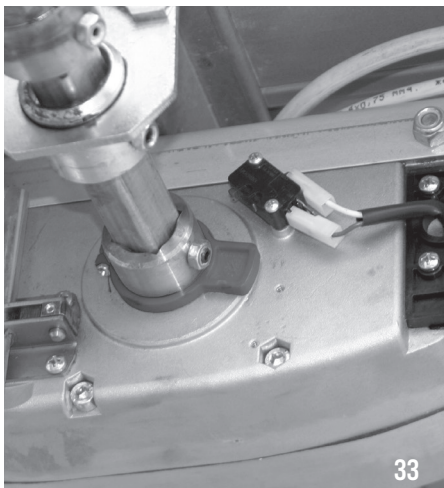

33



34

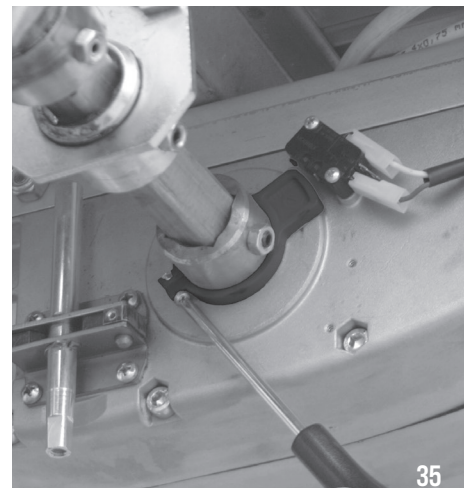

35

REGOLAZIONE FINECORSO CHIUSURA

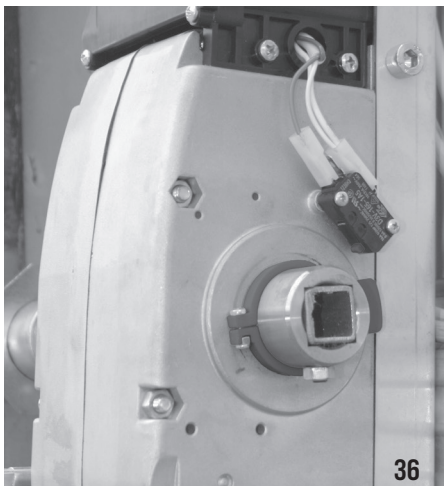

36

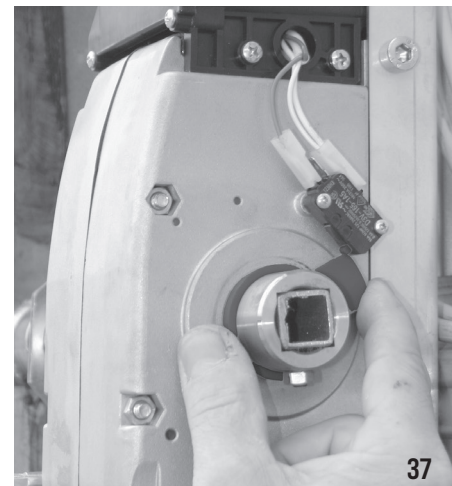

37

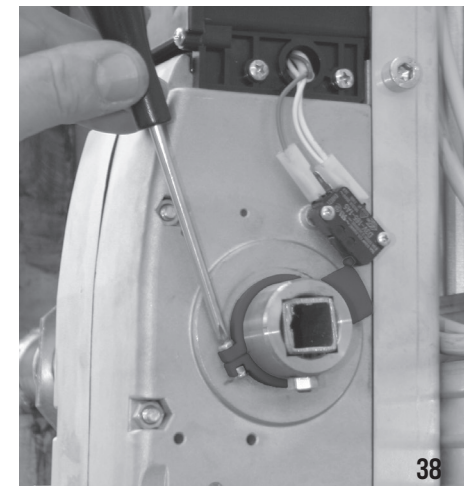

38

FISSAGGIO CARTER

- Eseguire il montaggio della manopola fissa (quella senza indicazione dello sblocco) sul carter utilizzando l'apposita vite, dado e rondella in dotazione, inserendoli dalla parte opposta dello sblocco (Fig. 39).
- Applicare il tappo cieco dalla parte da cui non sporge l'albero quadro di traino del riduttore (Fig. 46).
- Innestare il connettore del gruppo illuminatore con il connettore del cavetto che fuoriesce dal contenitore del quadro elettrico (Fig. 40 e 41).
- Inserire il carter sul riduttore facendo attenzione a inserirlo sul longherone negli appositi spazi e a centrare l'asta di sblocco con il foro sul carter. Fissare con le viti in dotazione il carter al motore (Fig. 43 e 44) e successivamente fissare la maniglia di sblocco (Fig. 45) all'asta di sblocco del motore.
- Applicare il tappo laterale (Fig. 47).

A questo punto l'operatore è installato e pronto per eseguire la manovra di apprendimento (vedere il capitolo PROGRAMMAZIONE).

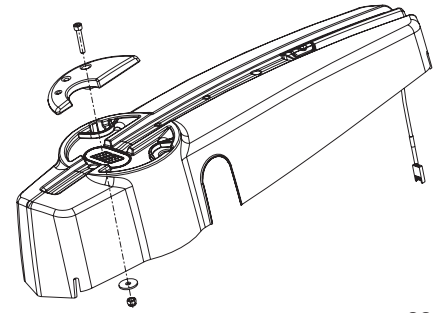

39

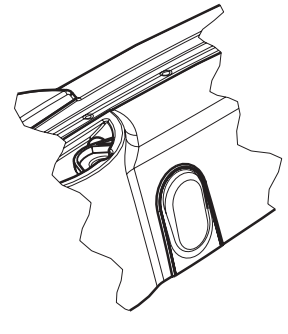
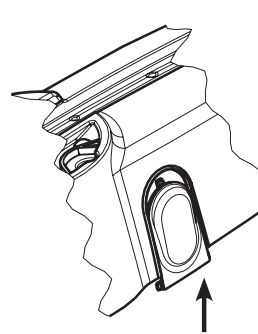
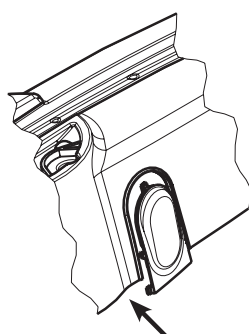
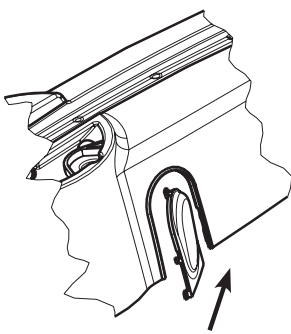
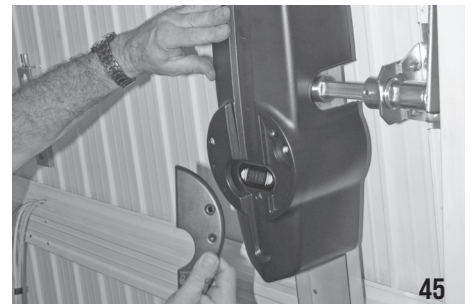

46

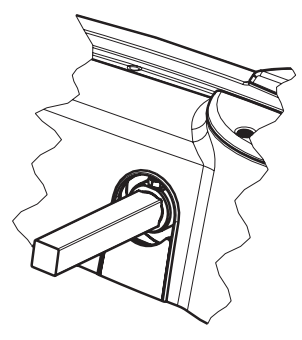
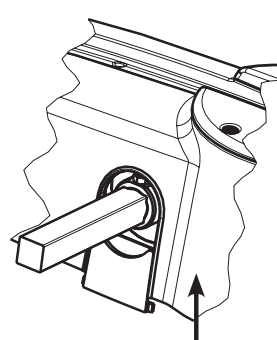
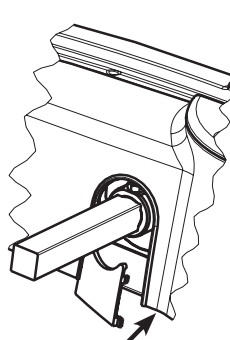
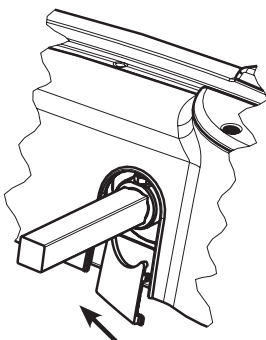

47

SBLOCCO INTERNO A MANIGLIA

BOSS viene normalmente fornito con una maniglia di sblocco azionabile dall'interno dell'abitazione (Fig. 48).

In caso di mancanza di energia elettrica ruotare entrambe le maniglie degli operatori per sbloccare il riduttore e aprire la porta manualmente.

Per bloccare i riduttori riportare le maniglie nella posizione iniziale.

Per poter eseguire in modo sicuro la movimentazione manuale dell'anta occorre verificare che:

- sulla porta siano fornite maniglie idonee;
- tali maniglie siano posizionate in modo da non creare punti di pericolo durante il loro utilizzo;
- lo sforzo manuale per muovere la porta non superi i 225N per le porte poste su siti privati ed i 390N per le porte poste su siti commerciali ed industriali (valori indicati nel punto 5.4.5 della norma EN 12453).

ATTENZIONE: L'attivazione dello sblocco può provocare un movimento non controllabile della porta in caso questa non sia correttamente equilibrata. In questo caso è necessario bilanciare correttamente la porta basculante.



SBLOCCO A FILO

Con questo tipo di sblocco è possibile sbloccare i motori dall'esterno in caso di black-out. È quindi consigliato quando non si hanno altri accessi al garage se non dalla porta basculante.

Il dispositivo di sblocco (cod. AC68734) viene applicato alla serratura esistente sulla porta basculante.

ATTENZIONE: se sono presenti 2 serrature sulla porta, applicare ad ogni serratura lo sblocco AC68730.

Per il montaggio vedere le istruzioni specifiche inserite nell'accessorio.

Seguire le immagini dalla Fig. 53 alla 64.

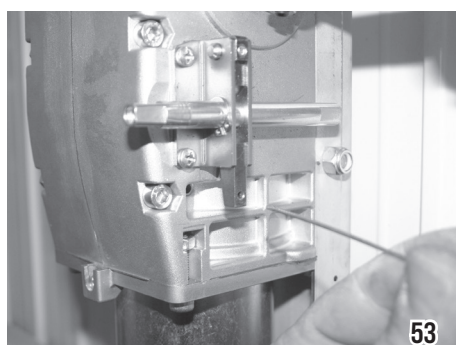
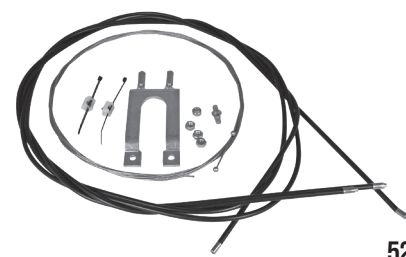

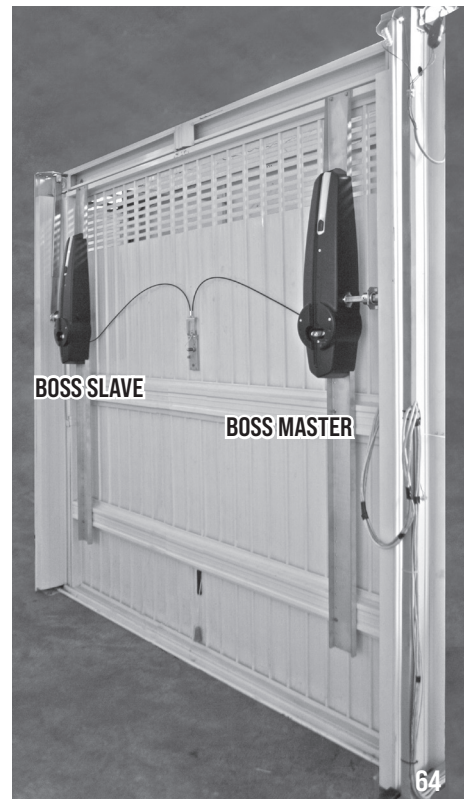
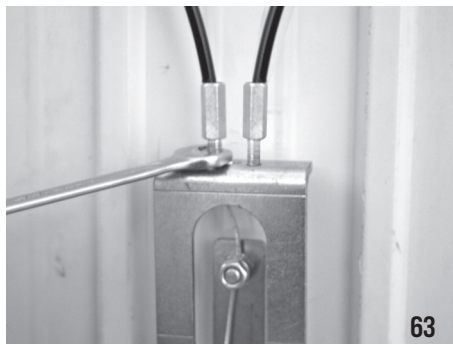
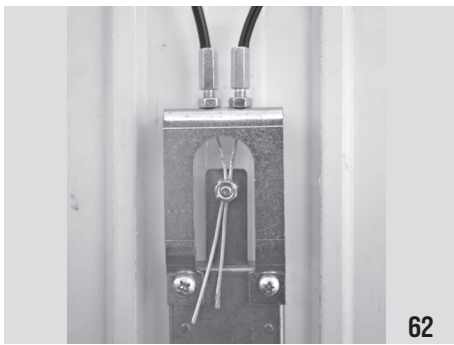

SBLOCCO CHIAVE A BRUGOLA CON SERRATURA

E' possibile effettuare lo sblocco dall'esterno, utilizzando l'accessorio cod.ACG8732 con chiave personalizzata.

Per il montaggio vedere le istruzioni specifiche inserite nell'accessorio.

Per effettuare l'operazione di sblocco dall'esterno eseguire queste semplici operazioni:

- Togliere il tamburo della serratura con apposita chiave (Fig. 66).

- Inserire una chiave a brugola n° 6 nel foro della piastrina fino a raggiungere la boccola di sblocco (Fig. 67).
- Ruotare la chiave esagonale nel senso indicato dall'adesivo applicato sulla basculante, fino ad ottenere lo sblocco dell'operatore (Fig. 68).
- Per bloccare il riduttore ruotare la chiave esagonale nel senso indicato dall'adesivo applicato sulla basculante (Fig. 68).



65



66



67

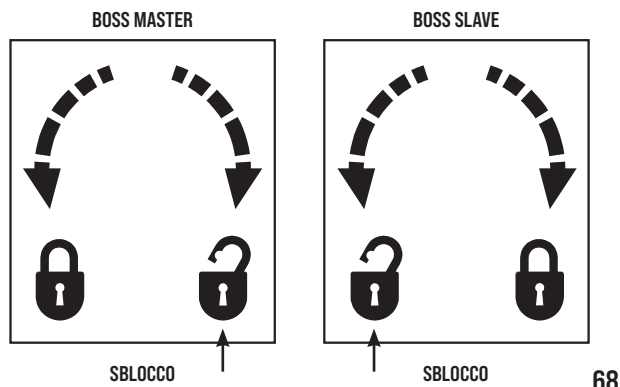

ATTENZIONE!

Il riaggancio dei vari sblocchi a porta chiusa non garantisce la totale chiusura della basculante, che rimarrà parzialmente aperta fino a quando non sarà eseguita una movimentazione elettrica. La corretta chiusura avverrà solamente a chiusura elettrica completata.

MANUTENZIONE

Da effettuare solamente da parte di personale specializzato dopo aver tolto l'alimentazione elettrica al motore.

Ogni anno ingrassare i cardini, le guide di scorrimento dei contrappesi, le leve telescopiche.

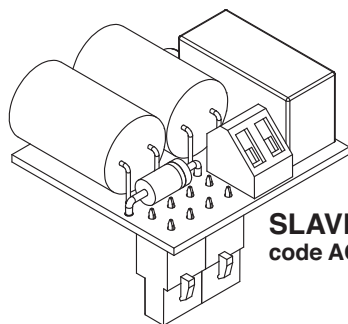

SLAVE CARD
code ACQ9087

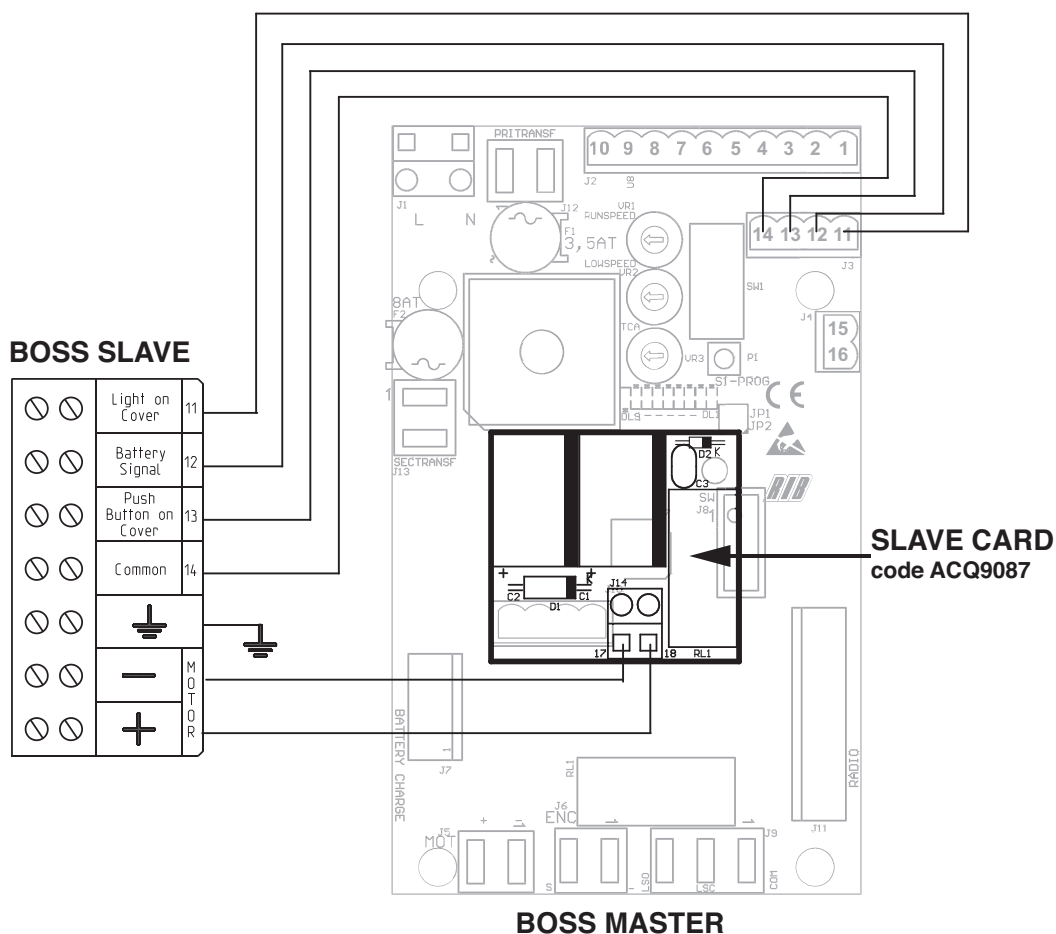

SLAVE CARD
code ACQ9087

BOSS MASTER

COLLEGAMENTI TRA MOTORE MASTER E MOTORE SLAVE

Tramite la scheda SLAVE è possibile comandare un 2° motore per applicazioni su basculanti con metrature superiori ai 9 m².

Dopo aver tolto l'alimentazione di rete dall'impianto, è sufficiente inserire la scheda SLAVE nel connettore J10.

La scheda si configura automaticamente all'accensione per il pilotaggio di 2 motori.

Collegare i 4 fili (sez. min. 0,5 mm²) dei morsetti 11-12-13-14 della scheda del motore MASTER ai morsetti 11-12-13-14 presenti nel contenitore a bordo del motore SLAVE.

Collegare i fili motore (sez. min. 1,5 mm²) dei morsetti 17-18 della scheda SLAVE ai morsetti e della morsettiera presente nel contenitore a bordo del motore SLAVE.

SICUREZZA PER PORTA PEDONALE - PEDESTRIAN SECURITY (morsetti 5-6)

Nel caso la basculante abbia una porta per passaggio pedonale, collegare un microinterruttore (N.C. a porta pedonale chiusa) che segnali alla centralina se la porta pedonale è aperta o chiusa.

Il collegamento deve essere eseguito tra i morsetti 5-6 (se nessuna costa collegata), oppure in serie al contatto della costa (se presente).

Per un corretto funzionamento del sistema, il led DL3 deve essere acceso segnalando che la porta pedonale è correttamente chiusa. Se il led DL3 è spento non si avrà nessuna movimentazione della basculante perché la porta pedonale è aperta.

se i morsetti 5-6 non vengono utilizzati da coste o altri dispositivi, eseguire un ponticello.

OPTIONAL

Per i collegamenti ed i dati tecnici degli accessori attenersi ai relativi libretti di istruzione.

SBLOCCO A FILO

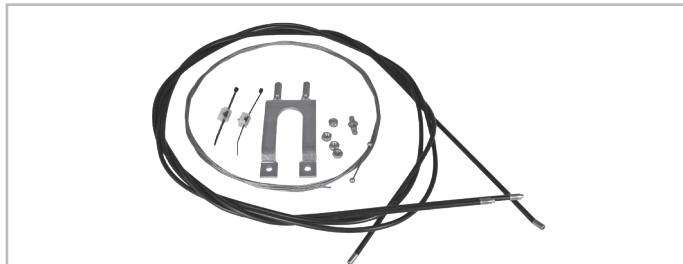

cod. ACG8734

SBLOCCO CHIAVE A BRUGOLA CON SERRATURA



cod. ACG8732

CARICA BATTERIE BOSS 24V

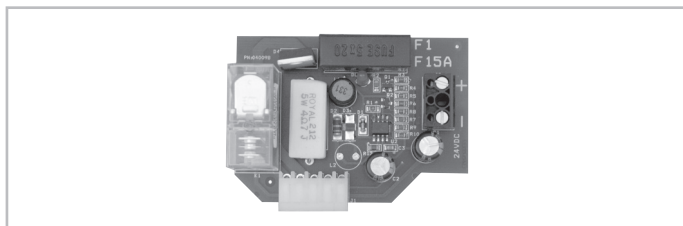

cod. ACG4663

CONTENITORE CON BATTERIE



cod. ACG2246

FIT SLIM



COPPIA FOTOCELLULE DA PARETE
COPPIA DI COLONNINE PER FIT SLIM
TRASMETTITORE TX SLIM SYNCRO

cod. ACG8032B
cod. ACG8065
cod. ACG8029B

FOTOCELLULE NOVA WIRELESS



Segnalazione batteria scarica - portata 30 m - durata batterie oltre 3 anni

cod. ACG8047
cod. ACG9519

BATTERIE ALCALINE 4 x 1,5V

TELECOMANDO SUN

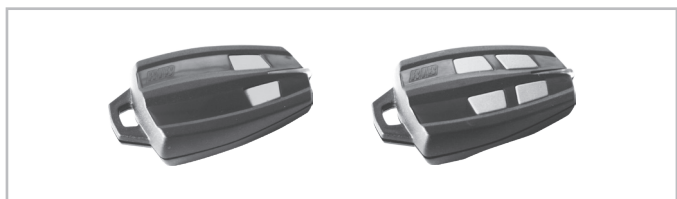

SUN 2CH
SUN CLONE 2CH

cod. ACG6052
cod. ACG6056

SUN 4CH
SUN CLONE 4CH

cod. ACG6054
cod. ACG6058

SAIL

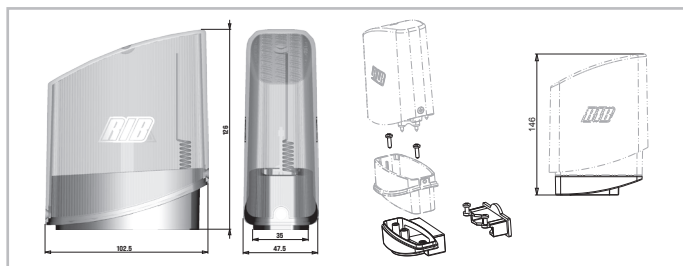

SAIL arancione con scheda intermittente incorporata
SAIL bianco con scheda intermittente incorporata
SUPPORTO LATERALE SAIL

cod. ACG7072
cod. ACG7078
cod. ACG8054

S18



S18 da incasso (NO+NO)
S18 da parete (NO+NO)

cod. ACG1054
cod. ACG1056

S18 da incasso (NO+NC)
S18 da parete (NO+NC)

cod. ACG1054S
cod. ACG1056S

Portes basculantes de 12 m² max.

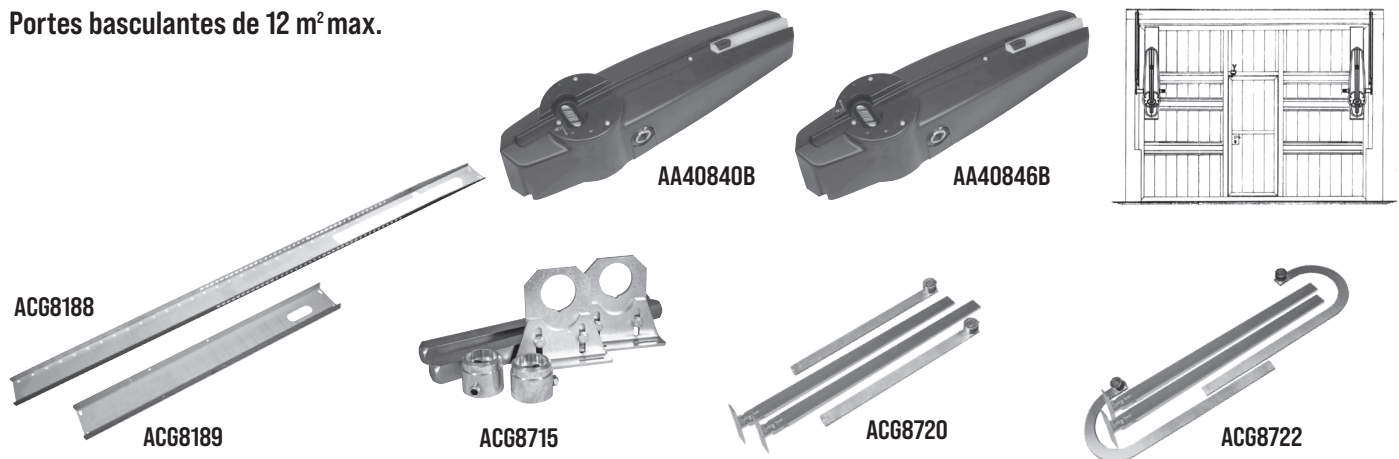

- n° 1 - AA40840B - BOSS 24V MASTER avec fin de course sans longeron
- n° 1 - AA40846B - BOSS 24V SLAVE sans longeron
- n° 2 - ACG8188 - Longeron L = 1,95 m pour bascule pas prévue à la motorisation (ou ACG8189 - Longeron L = 0,8 m pour bascule prévue à la motorisation)
- n° 1 - ACG8715 - Renvoi latéral pour 2 moteurs L= 30 cm
- n° 1 - ACG8720 - Paire de leviers droits (ou ACG8722 - Paire de leviers courbes)

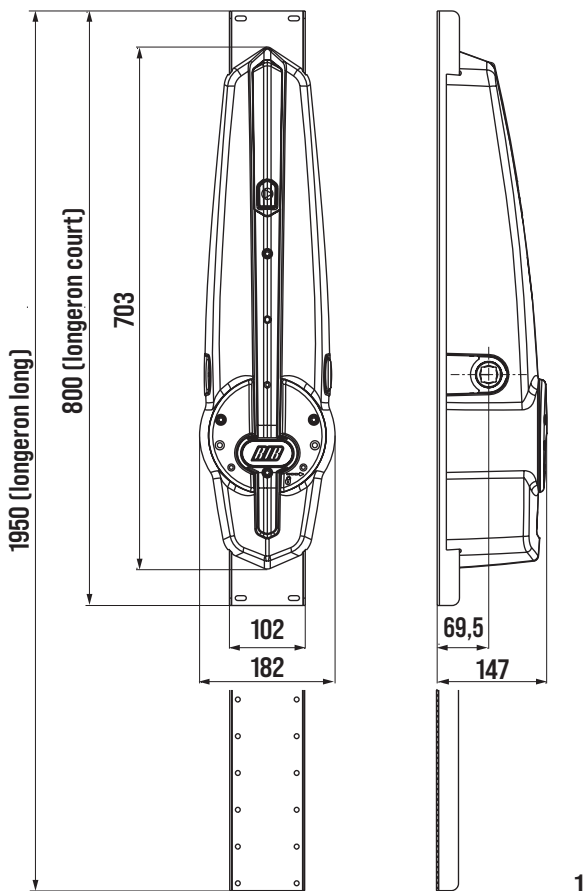

Mesures en mm

CARACTÉRISTIQUES TECHNIQUES

BOSS est un opérateur irréversible employé pour les portes basculantes équilibrées par contrepoids.

Il est pourvu d'un groupe réducteur lubrifié avec de la graisse synthétique, d'un déblocage manuel en cas de coupure de courant et d'un longeron **(en option)** pour fixer l'opérateur à la porte basculante.

BOSS est protégé des éclaboussures d'eau provenant de toutes les directions grâce à la protection IP44 de série.

BOSS 24V SLAVE, jumelé à BOSS 24V MASTER, est pourvu d'un éclairage à led, d'un réglage de la vitesse et d'un capteur d'impact conformément aux Normes Européennes en vigueur.

CARACTERISTIQUES TECHNIQUES		BOSS 24V MASTER + BOSS 24V SLAVE
Max. longueur levier basculante	cm	83
Max surface basculante	m ²	12
Max largeur basculante	m	6
Max. hauteur basculante	m	2,5
Couple maxi 1 moteur	Nm	350
Tours par minute de l'opérateur	rpm	1,8
Temps de ouverture réglable	s	15 ÷ 23
Alimentation de ligne		230V ~ 50Hz
Alimentation moteur		24Vdc
Puissance 1 moteur	W	55
Absorption ligne de réseau	A	1,2
Cycles normatifs	n°	∞ - 20s/2s
Cycles conseillés par jour	n°	36
Service		50%
Poids opérateur	kg	9,5 MASTER + 8 SLAVE
Bruit	db	<70
Temperature de travail	°C	-10 ÷ +55 °C
Indice de protection	IP	44

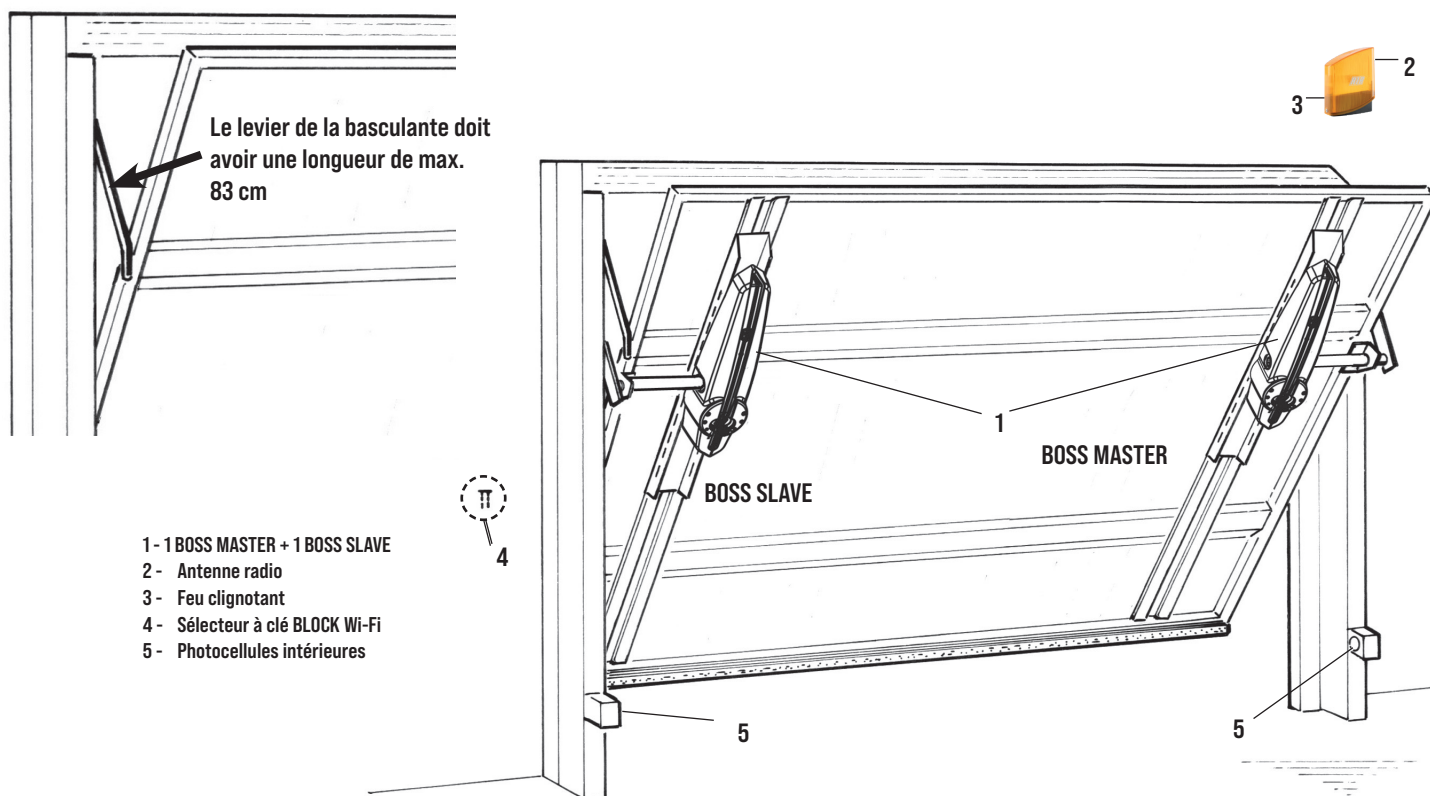

CONTROLE DE PRE-INSTALLATION

Pour des portes avec une largeur allant jusqu'à 6 m, hauteur maximale 2,5 m ou jusqu'à une superficie de 12 m² et levier de la basculante avec une longueur maximale de 83 cm, on utilise 2 BOSS (MASTER AA40840 + SLAVE AA40845) installés comme illustré sur la figure 3, une PAIRE DE LEVIERS DROITS cod. ACG8720 (ou une PAIRE DE LEVIERS COURBES cod. ACG8722), le RENVOI LATÉRAL pour 2 moteurs cod. ACG8715 et 2 cod. ACG8189 LONGERONS COURTS ou 2 cod. ACG8188 LONGERONS LONGS.

- Vérifier que l'espace compris entre le châssis mobile de la porte et les caissons contenant les contrepoids soit supérieur à 15 mm. Il est dans ce cas possible d'installer les LEVIERS DROITS. Si la distance est moins de 15 mm, il faut utiliser les LEVIERS COURBES en respectant les cotes de montage décrites sur la Fig. 4.
- Vérifier que les roulements de la porte basculante ne soient pas bloqués et que les cordes de fixation des contrepoids soient en bon état.
- S'il existe, enlever le levier de fermeture manuelle raccordé à la serrure.

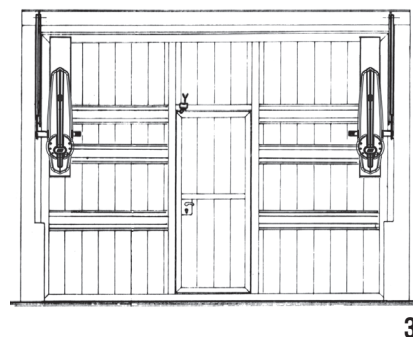

N.B. Il est obligatoire d'uniformiser les caractéristiques de la porte basculante aux normes et lois en vigueur. La porte basculante ne peut être automatisée que si elle est en bon état et si elle répond à la norme EN 12604.

Il ne faut pas créer de point de prise au piège (par exemple entre la porte basculante ouverte et le mur).

Parties à installer conformément à la norme EN 12453

TYPE DE COMMANDE	USAGE DE LA FERMETURE		
	Personne expertes (zone sans publique*)	Personne expertes (zone avec publique)	Personnes non expertes
homme presente	A	B	Pas possible
impulsion en vue (ex. bouton)	C ou E	C ou E	C et D, ou E
impulsion hors de vue (ex. télécommande)	C ou E	C et D, ou E	C et D, ou E
automatique	C et D, ou E	C et D, ou E	C et D, ou E

* exemple typique: fermetures qui n'ont pas d'accès à un chemin public

A: Touche de commande à homme present (à action maintenue), comme code ACG2013.

B: Sélecteur à clef à homme present (à action maintenue), code ACG1010.

C: Réglage de la puissance du moteur ou photocellules pour respecter les forces d'impact indiquées à l'annexe A

D: Barre palpeuse et/ou autres dispositifs supplémentaires pour réduire la probabilité de contact avec la porte.

E: Dispositifs installés de telle sorte qu'une personne ne puisse pas être touchée par la porte.

APPLICATION DES LEVIERS

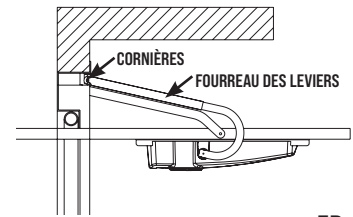
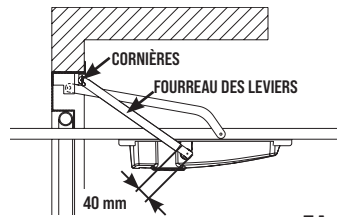
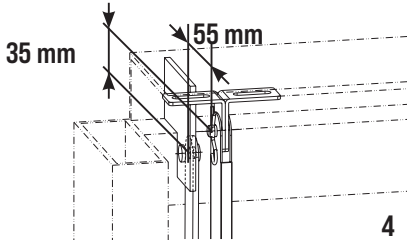

MONTAGE DE LA PAIRE DE LEVIERS DROITS (cod. ACG8720) ENTRE LE MOTEUR ET LE CHÂSSIS SUPÉRIEUR DE LA PORTE

NB: La PAIRE DE LEVIERS DROITS TÉLÉSCOPIQUES peut être montée lorsqu'entre la partie mobile de la porte et le caisson contenant le contrepois, il y a un espace de 15 mm minimum.

- Fixer avec des rivets ou des vis les cornières au châssis supérieur en respectant les mesures illustrées à la Fig. 4: si à l' hauteur de 35 mm, on trouve la plaque de renforcement du châssis de la basculante, il est possible de fixer les étriers directement sur la plaque même si l' hauteur ne sera pas respecté.

Si pour la porte basculante est prévue la motorisation, utiliser les points d'attache prévus à cet effet. **Ne pas utiliser les cornières fournies.**

- Insérez les fourreaux des leviers aux cornières et fixez-les avec les chevilles et goupilles fournies (Fig. 4).

- Faire attention à ce qu'une fois montés les fourreaux ne heurtent pas les leviers de mouvement de la porte basculante.

MONTAGE DE LA PAIRE DE LEVIERS COURBES (cod. ACG8722) ENTRE LE MOTEUR ET LE CHÂSSIS SUPÉRIEUR DE LA PORTE

N.B.: La PAIRE DE LEVIERS COURBES TÉLÉSCOPIQUES est nécessaire lorsque l'espace compris entre le châssis mobile de la porte et les caissons contenant les contrepois est moins de 15 mm.

- Si pour la porte basculante est prévue la motorisation, utiliser les points d'attache prévus à cet effet. **Ne pas utiliser les cornières fournies.**

- Insérez les fourreaux des leviers aux cornières et fixez-les avec les chevilles et goupilles fournies (Fig. 4).

- Faire attention à ce qu'une fois montés les fourreaux ne heurtent pas les leviers de mouvement de la porte basculante.

N.B.: La longueur du fourreau des leviers devra être modifiée en fonction de la hauteur de la porte basculante. Il est donc indispensable de raccourcir aussi bien le fourreau que le levier de sorte que le fourreau puisse se trouver à une distance de 40 mm du centre du pivot d'entraînement, lorsque la porte est ouverte, et que le levier n'entre pas en collision avec le pivot de rotation positionné sur les cornières (Fig. 5A)

APPLICATION D'UN LONG LONGERON (POUR PORTES BASCULANTES SANS MOTORISATION PRÉVUE)

Cod. ACG8188

Positionner le longeron en tenant la partie supérieure (fente pour le passage des câbles électriques) tournée vers le haut (Fig. 6).

Fixer le longeron à ras de la partie mobile supérieure de la porte basculante loin 17 cm du fil intérieur du fourreau en utilisant pour le fixer des vis autotaraudeuses 6,3x13 non fournies.

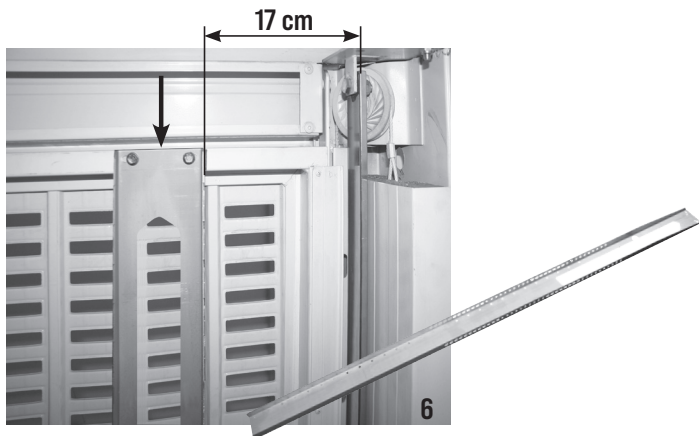

APPLICATION DU LONGERON COURT (POUR PORTES BASCULANTES AVEC MOTORISATION PRÉVUE)

Cod. ACG8189

Calculer la cote $L = C - 410$ [mm] à laquelle doit être fixé verticalement le longeron (Fig. 7-8). Veuillez le positionner sur les renforts verticaux en tenant la partie supérieure (fente pour le passage des câbles électriques) tournée vers le haut en position verticale. Fixer ensuite le longeron loin 17 cm du fil intérieur du fourreau à l'aide des 4 fentes passantes à l'aide de 4 vis métriques M6x25 et d'écrous autobloquants non fournis.

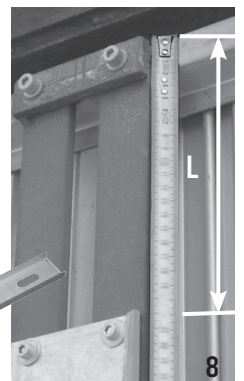
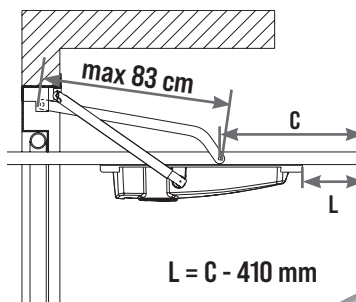

Après l'achèvement du montage, soit avec le LONGERON LONG, soit avec le LONGERON COURT, l'axe du arbre de sortie du réducteur doit être placé à une distance de 80 ± 10 mm de l'axe du pivot du petit bras de la porte basculante.

MONTAGE DES OPÉRATEURS

- Fixer BOSS au longeron avec les vis fournies (Fig. 9-10-11-12).
- Vérifier si la porte basculante est bien équilibrée.
Dans le cas contraire et dans le cas de porte non motorisée, ajouter 9 kg à chaque contrepoids pour bien équilibrer la porte.

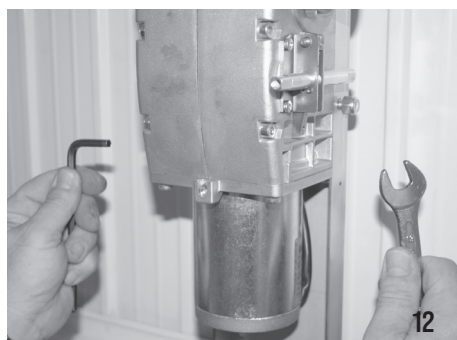
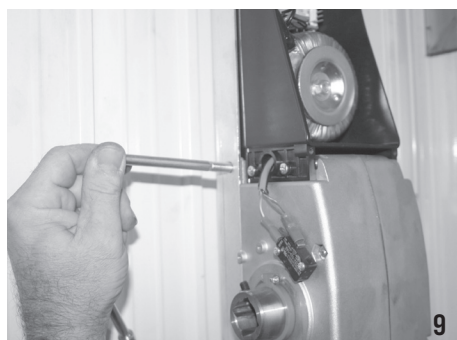

INTRODUCTION DU ARBRE PANNEAU DE TRANSMISSION DANS LES OPERATEURS

- Introduire le arbre panneau de transmission dans l'arbre de sortie de l'opérateur (Fig. 13).

ÉQUILIBRER A NOUVEAU LA BASCULANTE

Lorsque on applique 2 BOSS à la basculante les contrepoids doivent etre rendus plus lourds de 9 kg pour chaque partie.

FIXATION DU GROUPE RENVOI LATÉRAL 2 MOTEURS

- Introduire les bagues avec les goujons sur l'arbre panneau 20x20 (Fig. 14).
- Fixer les cornières de support réglables au châssis mobile de la porte basculante en axe avec l'arbre panneau (Fig. 15). **ATTENTION: les vis pour la fixation ne sont pas fournies.**
- Introduire les bagues dans les supports (Fig. 16) en tirant les boulons (Fig. 17).
- Vérifier que les LEVIERS DROITS (cod. AC68720) soient parfaitement perpendiculaires et ne heurtent pas les caissons des contrepoids ou la partie mobile de la porte. Si l'espace entre le châssis mobile de la porte et les caissons contenant les contrepoids est moins de 15 mm, utiliser la PAIRE DE LEVIERS COURBES (cod. AC68722) (en respectant toujours les mesures de la Fig. 4).

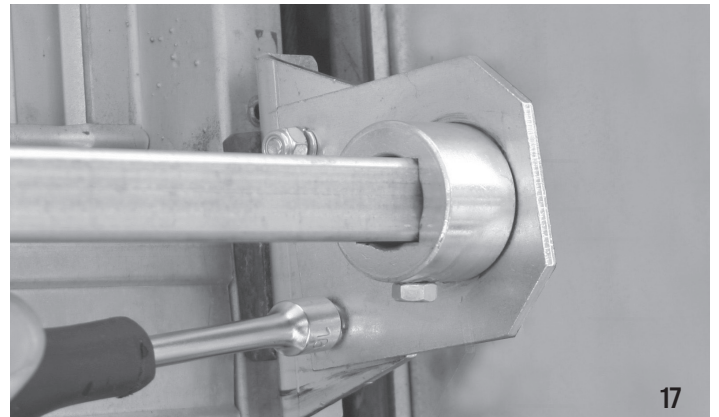
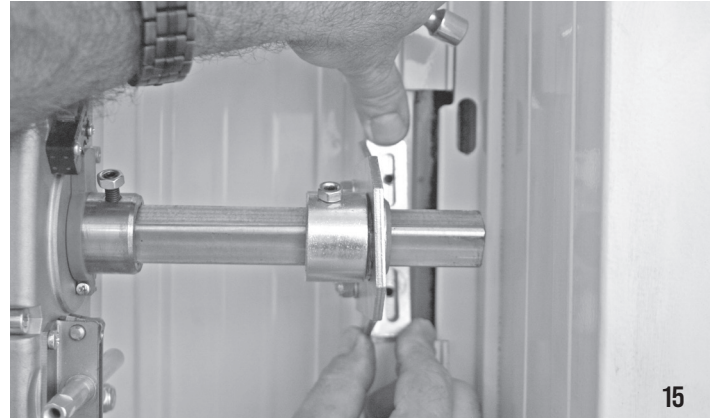
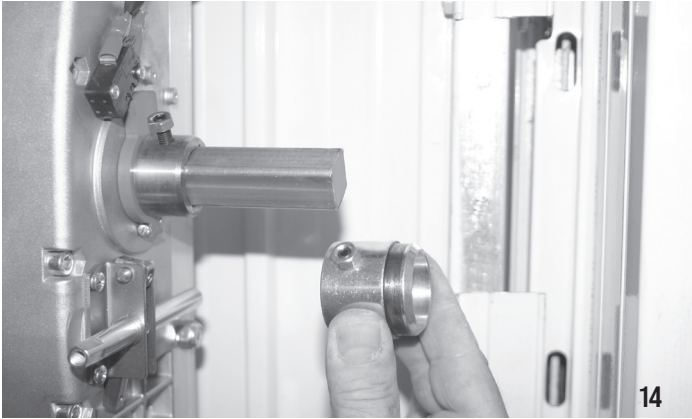

FIXATION DU TUBE ET DES LEVIERS DE RENVOI LATÉRAL

- Enfiler le levier dans le fourreau et introduire la bague soudée sur l'arbre panneau (Fig. 18).
- commencer à bloquer les goujons se trouvant sur l'arbre de traction (Fig. 19-20) sur les bagues de centrage et les contre-écrous (Fig. 21).
- Fixer ensuite avec le goujon et le contre-écrou les leviers au tube (Fig. 22-23).
- Débloquer mécaniquement les opérateurs en utilisant la poignée en dotation insérée dans les relatifs goujons de déblocage (Fig. 24-25).
- Vérifier le correct mouvement, ensuite bloquer de nouveau les opérateurs.
- Lubrifier avec du gras les chemins de la basculante.

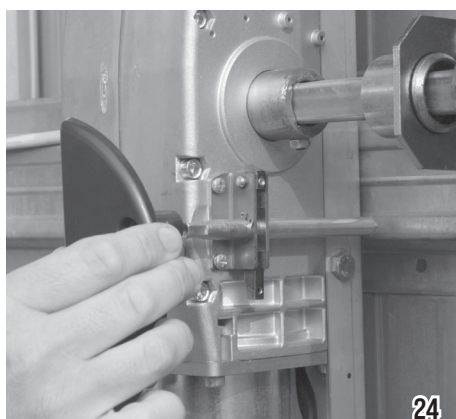
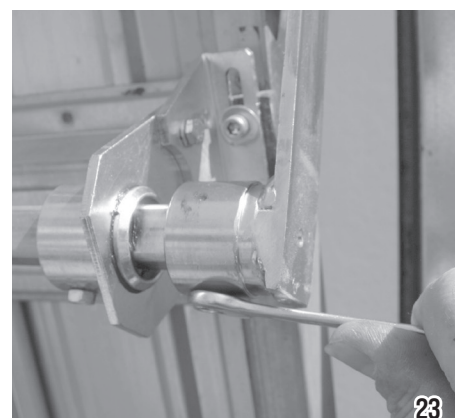
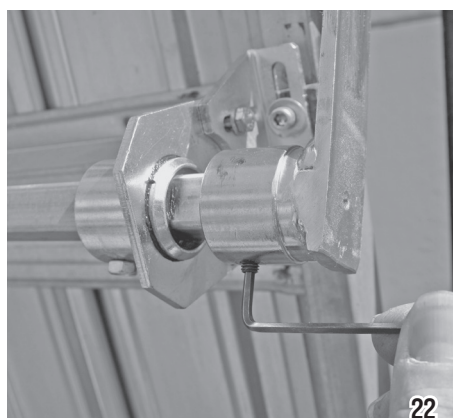
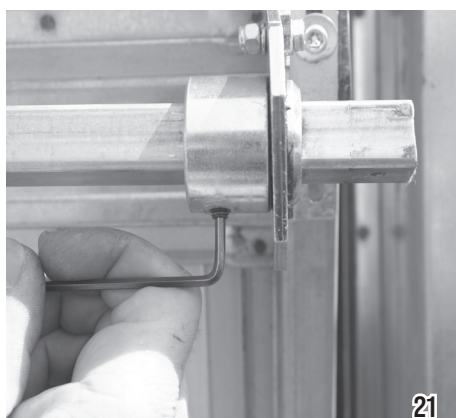
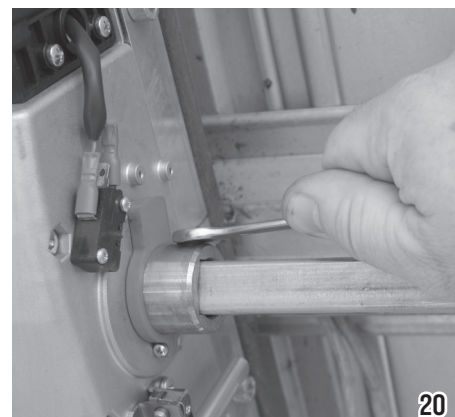
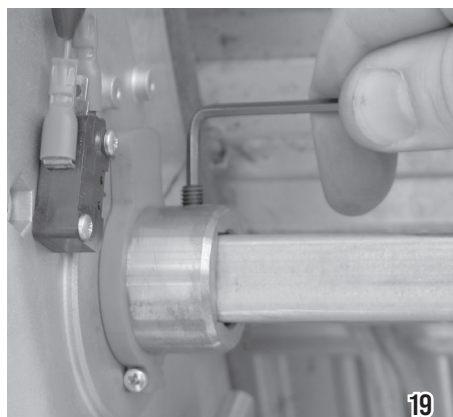

RACCORDEMENT ÉLECTRIQUE

Après avoir enlevé le couvercle du conteneur du cadre électrique, soit sur le reducteur MASTER que SLAVE (Fig. 26), insérer le coffret SLAVE sur le coffret à bord du reducteur MASTER (Fig. 30-31), en coinçant l'entretoise dans l'approprié trou (Fig. 30), effectuer les raccordements électriques comme illustré à la Fig. 69 pour pouvoir commander avec l'aide d'une personne la porte basculante.

ATTENTION: pour garantir l'IPX4, il faut nécessairement monter les passe-câbles en caoutchouc se trouvant dans le tableau électronique dans les trous sur le conteneur (Fig. 27) et monter la garniture ronde à fil ouvert sur le couvercle de fermeture (Fig. 28).

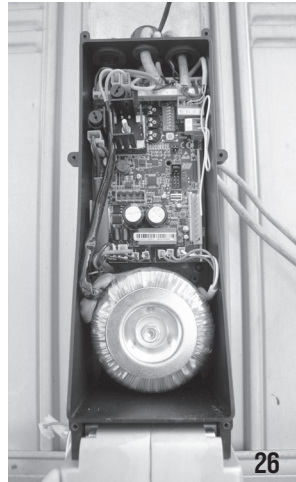

26

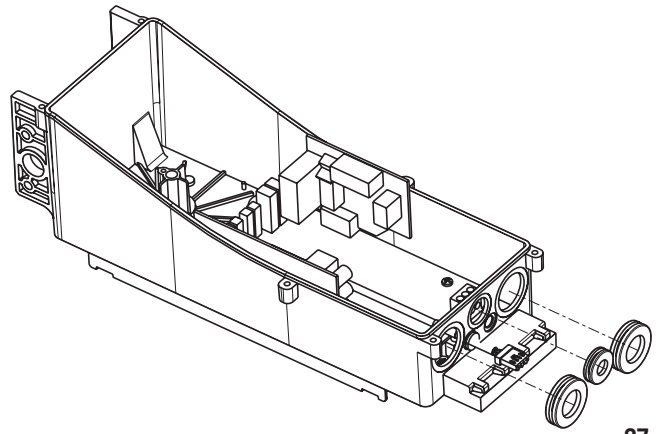

27

FIXATION DU CÂBLE ÉLECTRIQUE COTE OPERATEUR MASTER

Le câble électrique alimentant l'opérateur ne doit PAS être fixé au levier télescopique (Fig. 29). Le câble devra former une courbe afin que les mouvements de la porte dans ses mouvements ne soit pas sujets à des tensions ou des à-coups. Nous vous conseillons de protéger le câble à la sortie de l'orifice de la tôle de la porte avec une gaine pour éviter qu'il ne se coupe pendant le mouvement.

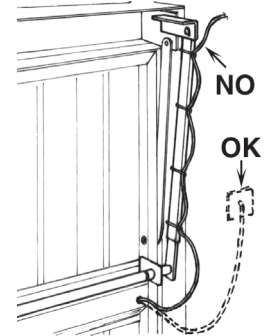

29

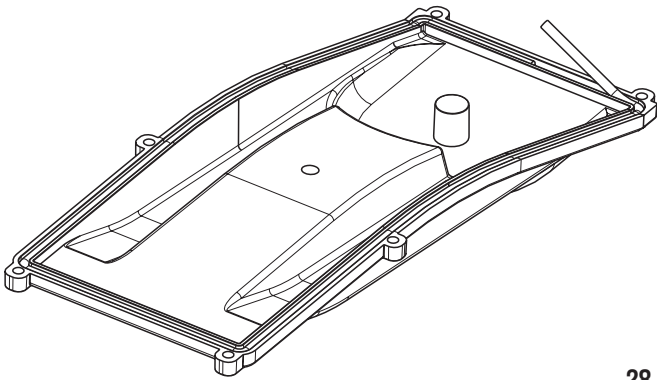

28

RÉGLAGE DU FIN DE COURSE POUR OPÉRATEUR MASTER

- Positionner le DIP 8 sur ON et appuyer sur la touche se trouvant sur le tableau électronique (Fig. 31) pour ouvrir la porte basculante. Relâcher la touche lorsque la porte est complètement ouverte. Dévisser la vis bloquant la came verte et la faire tourner jusqu'à faire déclencher le microinterrupteur (Fig. 34).
- Serrer la vis bloquant la came verte (Fig. 35).
- Appuyer sur la touche se trouvant dans le tableau électronique (Fig. 31) pour refermer la porte basculante. Relâcher la touche lorsque la porte est complètement fermée. Dévisser la vis bloquant la came rouge et la faire tourner jusqu'à faire déclencher le microinterrupteur (Fig. 37).
- Serrer la vis bloquant la came rouge (Fig. 38).
- Effectuer un cycle complet d'ouverture et de fermeture pour vérifier que les cames sont bien positionnées. Corriger la position à l'occurrence.
- Positionner le DIP8 sur OFF.

Pour la connexion des accessoires et les fonctionnalités du tableau, consulter le chapitre RACCORDEMENTS ÉLECTRIQUES.

Refermer la boîte électrique avec le couvercle en utilisant les 6 vis fournies.

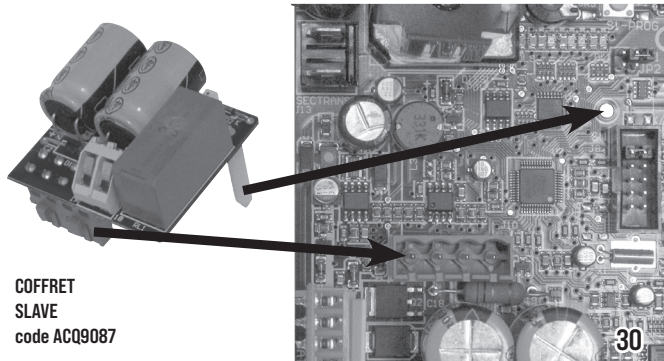

COFFRET SLAVE code ACQ9087

30

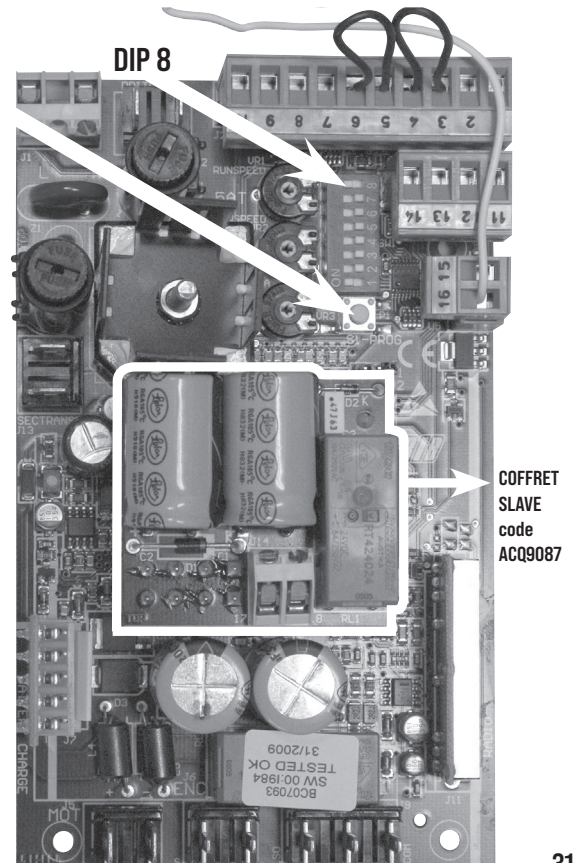

COFFRET SLAVE code ACQ9087

31

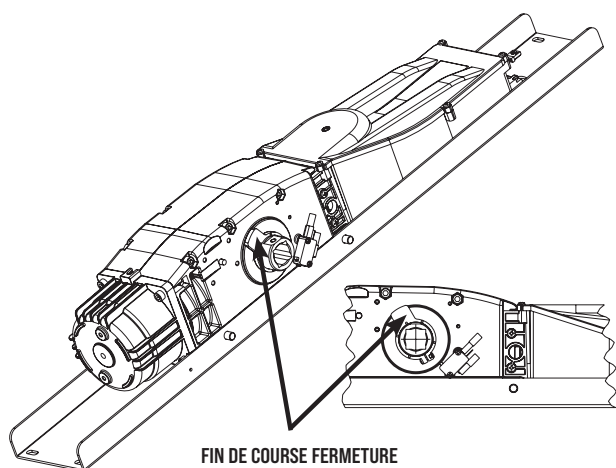

FIN DE COURSE FERMETURE
CAME ROUGE

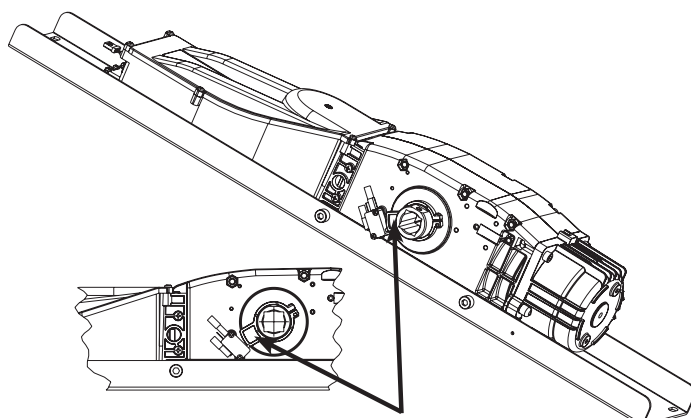

FIN DE COURSE OUVERTURE
CAME VERTE

32

RÉGLAGE DU FIN DE COURSE OUVERTURE



33



34

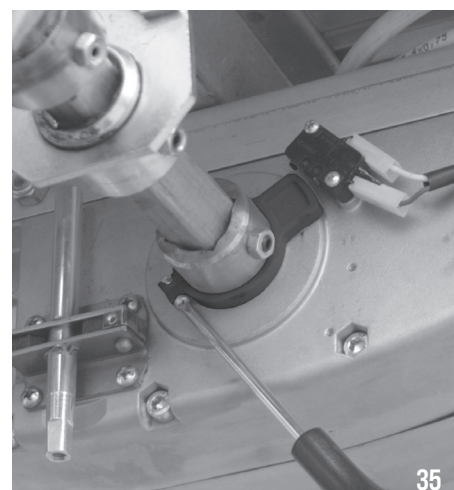

35

RÉGLAGE DU FIN DE COURSE FERMETURE

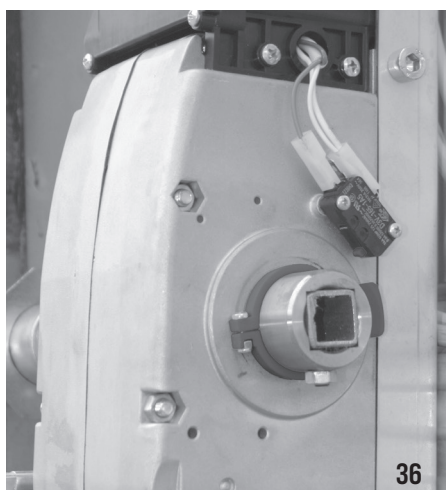

36

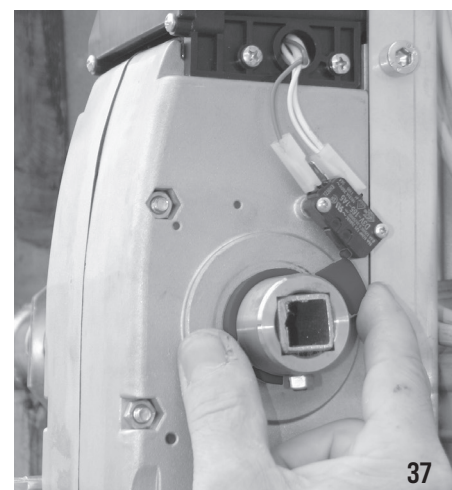

37

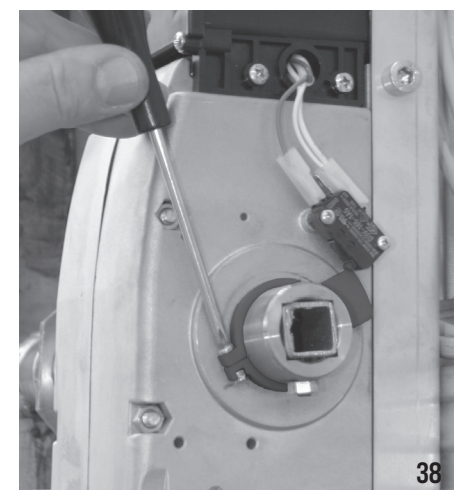

38

FIXATION DU CARTER

- Monter le bouton rotatif fixe (celui sans indication de déblocage) sur le carter à l'aide des vis, de l'écrou et de la rondelle prévus à cet effet, en les introduisant dans la partie opposée du déblocage (Fig. 39).
 - Appliquer le bouchon aveugle de la partie dont l'arbre panneau de traîne du reducteur ne s'oppose pas (Fig. 46).
 - Raccorder le connecteur du groupe d'éclairage avec le connecteur du câble sortant de la boîte du tableau électrique (Fig. 40 e 41).
 - Introduire le carter sur le réducteur en faisant attention à l'introduire sur le longeron dans les espaces prévus et à centrer la tige de déblocage avec le trou sur le carter. Fixer à l'aide des vis fournies le carter au moteur (Fig. 43 e 44) et fixer ensuite la poignée de déblocage (Fig. 45) à la tige de déblocage du moteur.
 - Appliquer le bouchon latéral (Fig. 47).
- L'opérateur est alors installé et prêt à effectuer la manœuvre d'apprentissage (voir le chapitre PROGRAMMATION).

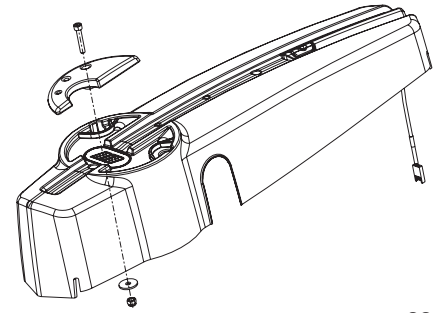

39



40



41



42



43



44

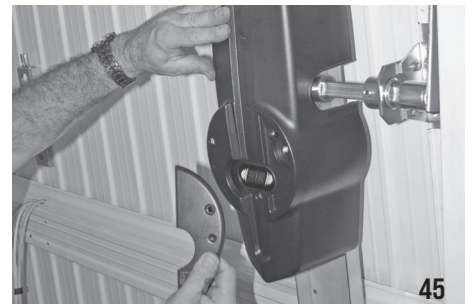

45

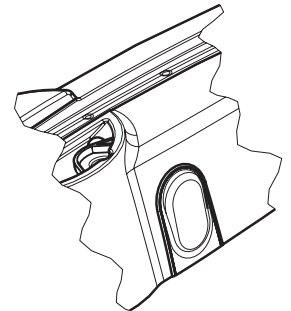
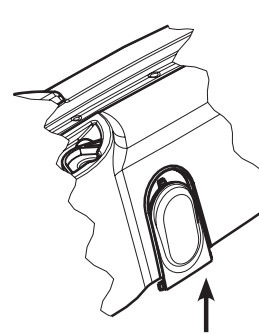
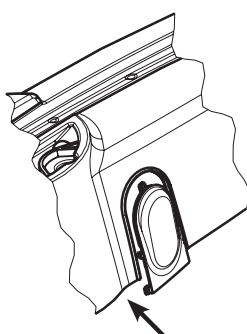
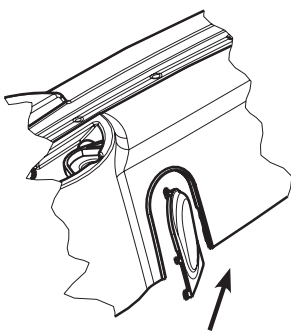

46

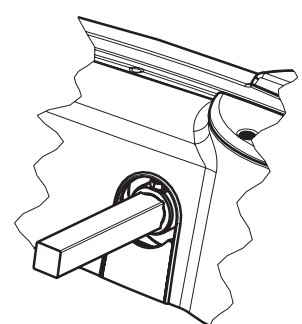
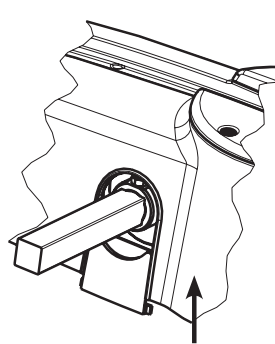
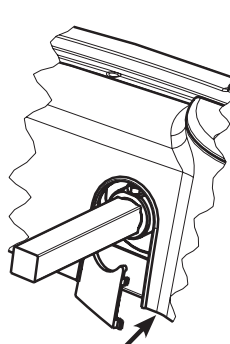
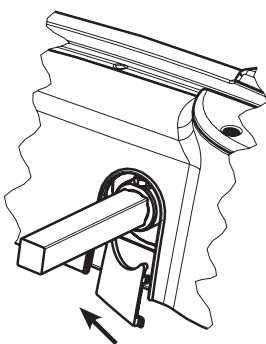

47

DÉBLOCAGE INTERNE À POIGNÉE

BOSS est généralement livré avec une poignée de déblocage pouvant être actionnée de l'intérieur de l'habitation (Fig. 48).

En cas de coupure de courant tourner toutes les deux les poignées des opérateurs pour débloquer les réducteurs et ouvrir la porte manuellement.

Ramener le poignées dans sa position initiale pour bloquer les réducteurs.

Pour pouvoir effectuer les mouvements manuels de la porte, veuillez vérifier que:

- la porte ait des poignées appropriées;
- la position de ces poignées ne crée pas des points de danger pendant leur utilisation;
- l'effort manuel pour le mouvement de la porte ne dépasse pas 225N pour les portes sur les sites privés et 390N pour les portes sur les sites commerciaux et industriels (valeurs indiquées au point 5.4.5 de la norme EN 12453).

ATTENTION: Le fait d'activer le déblocage peut provoquer un mouvement incontrôlé de la porte si celle-ci n'est pas équilibrée correctement. Dans ce cas, il faut bien rééquilibrer la porte basculante.



48



49



50



51

DEBLOCAGE A FIL

Avec ce type de déblocage, il est possible débloquer les moteurs de l'extérieur en cas de black-out.

Donc, il est conseillé quand on a accès au garage seulement de la porte basculante.

Le dispositif de déblocage (cod. AC68734) est appliqué à la serrure existante sur la porte basculante.

ATTENTION: si Vous avez 2 serrures sur la porte, appliquer à chaque serrure le déblocage AC68730.

Pour le montage voir les instructions spécifiques insérées dans l'accessoire.

Suivre les images de la Fig. 53 à la 64.

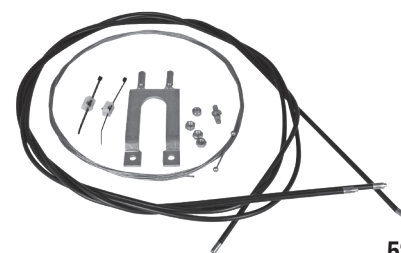

52

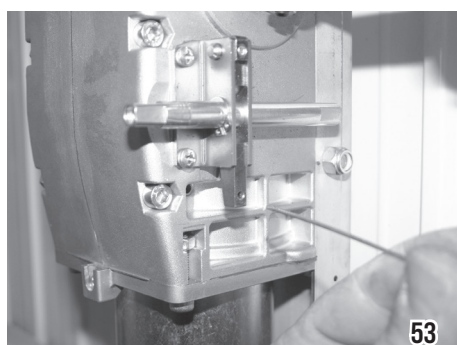

53



54

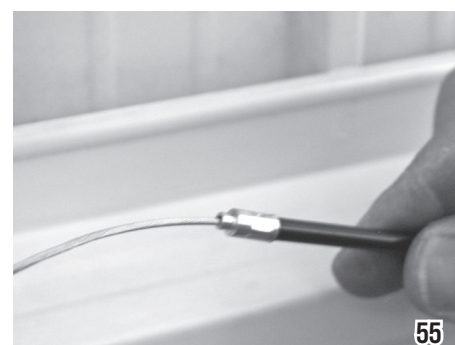

55



56

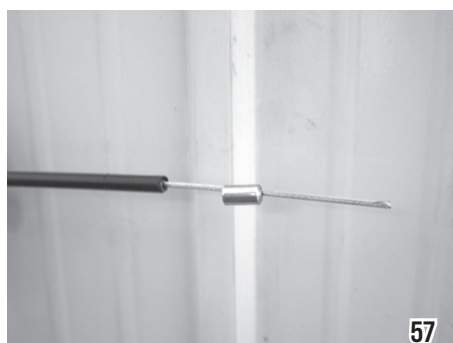

57



58

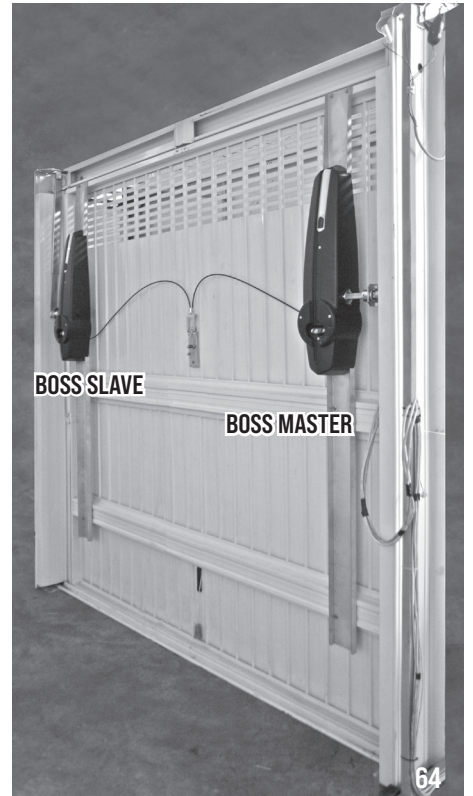
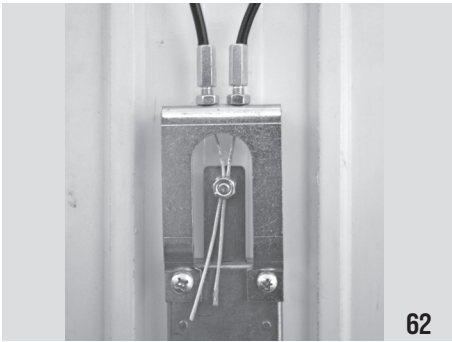

DEBLOCAGE CLE D'ALLEN AVEC SERRURE

Il est possible de débloquer la porte de l'extérieur à l'aide de l'accessoire cod. ACG8732 avec clé personnalisée.

Pour le montage voir les instructions spécifiques insérées dans l'accessoire.

Pour effectuer le déblocage de l'extérieur, suivre les opérations ci-dessous:

- Enlever le tambour de la serrure à l'aide d'une clé appropriée (Fig. 66).

- Introduire une clé Allen n°6 dans le trou de la plaque jusqu'à atteindre la bague de déblocage (Fig. 67).
- Tourner la clé dans le sens indiqué par l'étiquette appliquée sur la basculante, jusqu'à ce que l'opérateur se déblocue (Fig. 68).
- Pour bloquer le réducteur, tourner la clé hexagonale dans le sens indiqué par l'étiquette appliquée sur la basculante (Fig. 68).



65



66



67

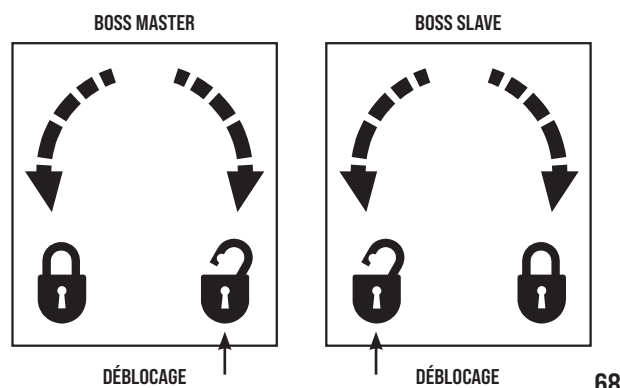

68

ATTENTION !

Je raccroche des divers déblocages à porte fermée ne garantit pas la totale fermeture de la basculante, qui restera partiellement ouverte jusqu'à lorsque sera exécutée une movimentazione électrique. La correcte fermeture sera seulement à fermeture électrique complétée.

ENTRETIEN

Effectuer seulement par personnel spécialisé après avoir coupé l'alimentation.

Graisser chaque année les gonds, les guides de coulissement des contrepoids et les leviers télescopiques.

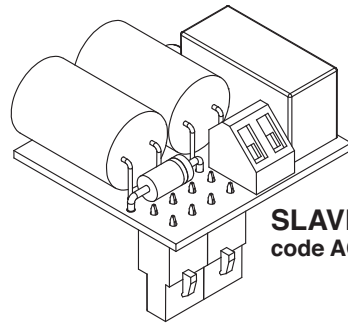

SLAVE CARD
code ACQ9087

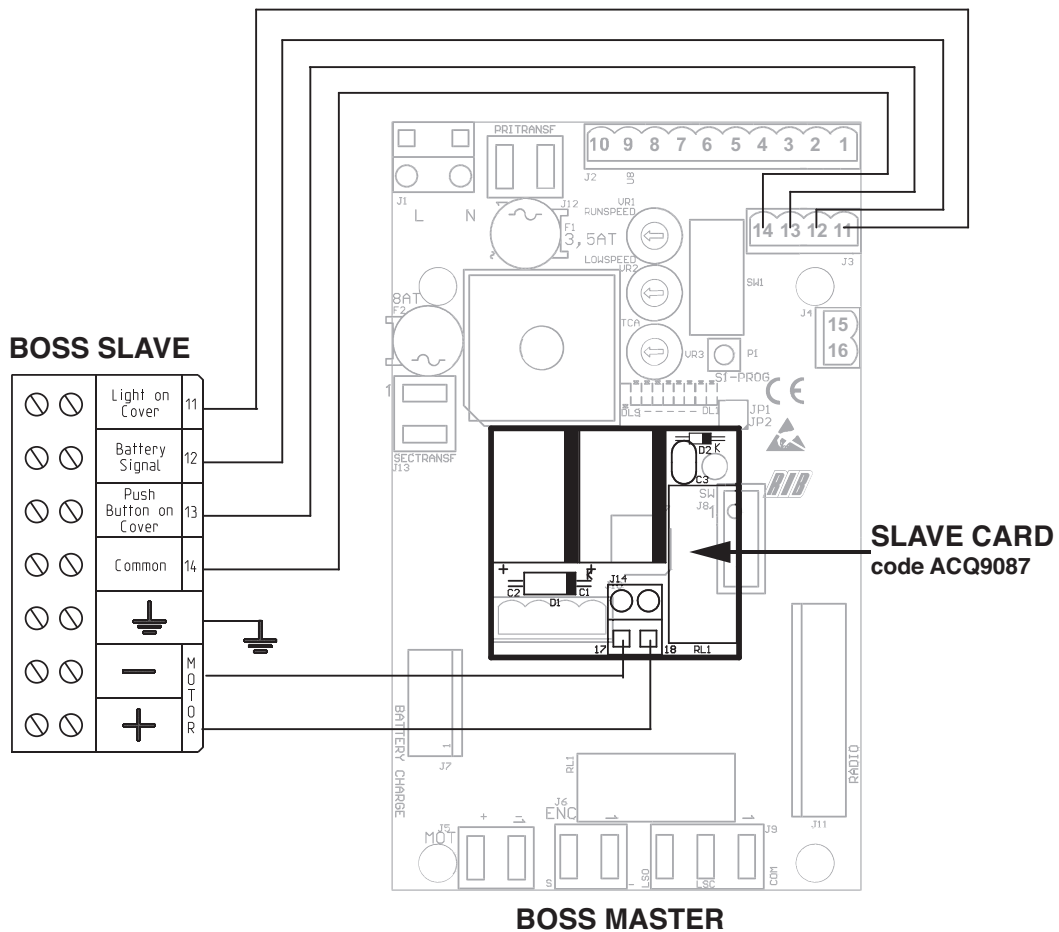

SLAVE CARD
code ACQ9087

BOSS MASTER

LIAISONS PARMi MOTEUR MASTER ET MOTEUR SLAVE

La carte SLAVE permet de commander un 2^e moteur pour des application sur des portes basculantes de plus de 9 m².

Après avoir coupé le courant de réseau, il suffit d'introduire la carte slave dans le connecteur J10.

La carte se configure automatiquement au démarrage pour le pilotage de 2 moteurs.

Relier le 4 fils (sec.min. 0,5 mm²) des bornes 11-12-13-14 de le coffret du moteur MASTER aux bornes 11-12-13-14 présents dans le container à bord du moteur SLAVE.

Relier les fils moteur (sec. min.1,5 mm²) des bornes 17-18 de le coffret SLAVE aux bornes - e + de la plaque à bornes présente dans le container à bord du moteur SLAVE.

SÉCURITÉ POUR PORTE PIÉTONNIÈRE - PEDESTRIAN SECURITY (bornes 5-6)

Si la porte basculante a une porte donnant sur un passage piétonnier, raccorder un microinterrupteur (N.C. avec la porte sur le passage piétonnier fermée) signalant à la centrale si la porte est ouverte ou fermée.

Le raccordement doit être effectué entre les bornes 5-6 (si aucune côte n'est branchée) ou en série en contact avec la côte (si présente).

Pour que le système fonctionne correctement, la led DL3 doit être allumée en signalant que la porte piétonnière est correctement fermée. Si le led DL3 est éteint, on aura aucun mouvement de la basculante parce- que la porte pour piétons est ouverte.

NOTE: si les bornes 5-6 ne sont pas utilisées par les côtes ou d'autres dispositifs, effectuer un cavalier.

OPTIONS

Pour les branchements et les données techniques des accessoires, se conformer aux livrets d'instruction correspondants.

DEBLOCAGE A FIL

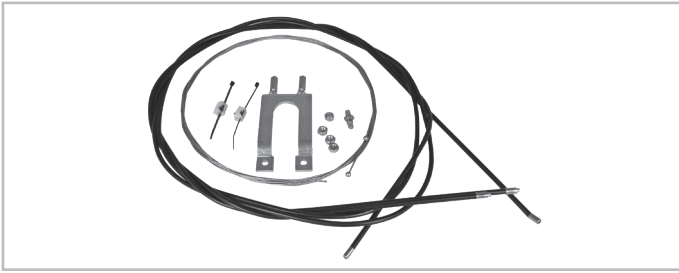

code ACG8734

DEBLOCAGE CLE D'ALLEN AVEC SERRURE



code ACG8732

FICHE DE CHARGE BATTERIE BOSS 24V

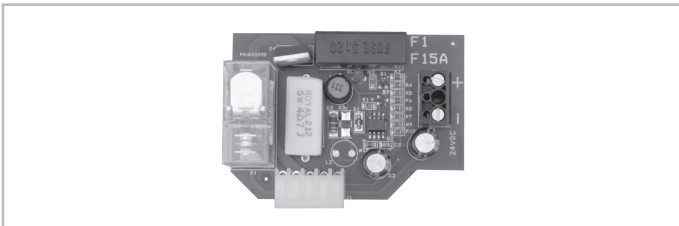

code ACG4663

CONTAINER AVEC BATTERIES



code ACG2246

FIT SLIM



PAIRE DE PHOTOCELLES MURALES
PAIRE DE POTEAUX POUR PHOTOCEL. FIT SLIM
TRANSMETTEUR TX SLIM SYNCRO

code ACG8032B
code ACG8065
code ACG8029B

PHOTOCELLULES NOVA WIRELESS



Signalisation batterie déchargée - portée 30 m - durée batteries de plus de 3 années

code ACG8047
code ACG9519

BATTERIES AA 4 x 1,5V

EMETTEUR RADIO SUN



SUN 2CH code ACG6052
SUN CLONE 2CH code ACG6056

SUN 4CH code ACG6054
SUN CLONE 4CH code ACG6058

S18



S18 encastrable (NO+NO) code ACG1054
S18 mural (NO+NO) code ACG1056

S18 encastrable (NO+NF) code ACG1054S
S18 mural (NO+NF) code ACG1056S

SAIL

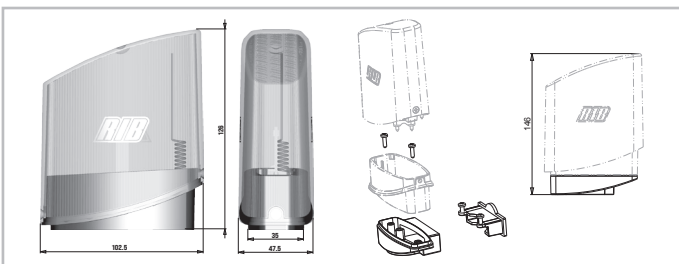

SAIL orange avec panneau clignotant intégré
SAIL blanc avec panneau clignotant intégré
SUPPORT LATÉRAL SAIL

code ACG7072
code ACG7078
code ACG8054

TECHNICAL DATA / INSTALLATION BOSS 24V SLAVE

Doors of max. max 12 / 0,47 m²/in²

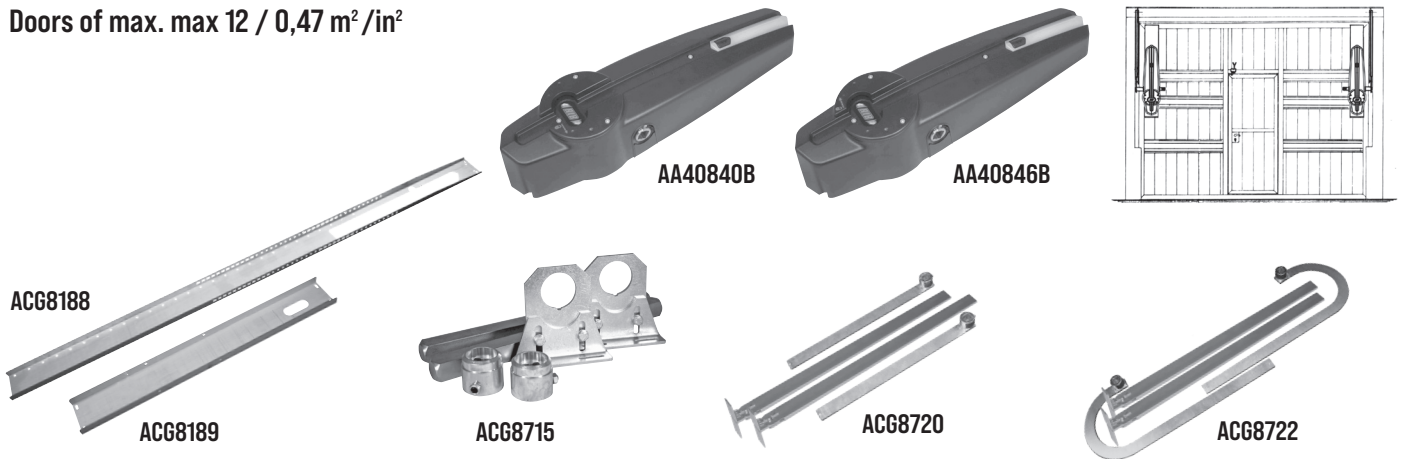

- No. 1 - AA40840B - BOSS 24V MASTER with limit switches, without mounting plate
- No. 1 - AA40846B - BOSS 24V SLAVE without mounting plate
- No. 1 - ACG8188 - Mounting plate L = 1,95 m for manual up-and-over applications
- No. 1 - ACG8189 - Mounting plate L = 0,8 m for automated up-and-over applications
- No. 1 - ACG8715 - Lateral transmission for 2 operators L = 30 cm
- No. 1 - ACG8720 - Pair of straight levers (or ACG8722 - pair of curved levers).

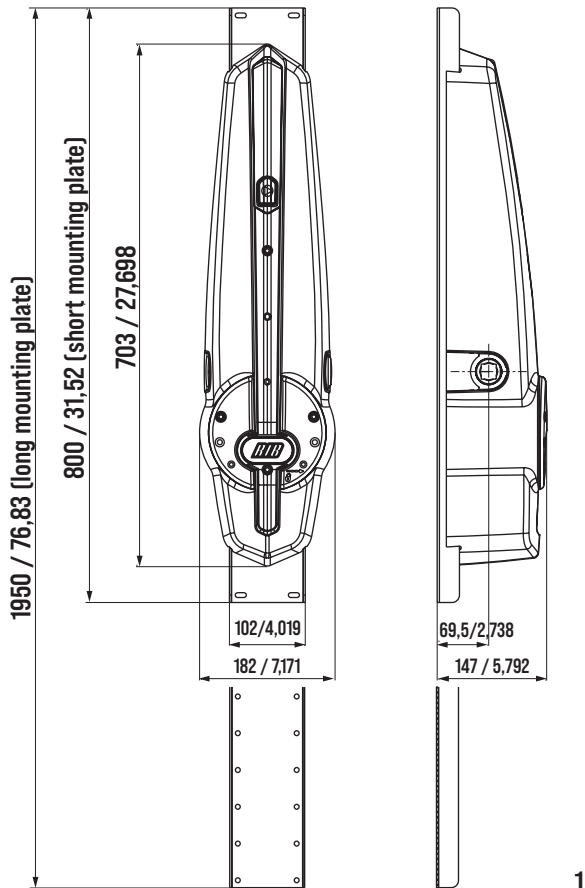

Measurements in mm/in

TECHNICAL FEATURES

BOSS is an irreversible operator employed for counterweight up-and-over garage doors. The system comprises a reducer unit, lubricated with synthetic grease, a manual release device in the absence of a power supply, and mounting plate (optional) to fasten the operator to the tilting roller device. IP44 series protection safeguards BOSS against any sprays of water from any direction. BOSS 24V SLAVE, paired with BOSS 24V MASTER, is equipped with an LED lamp, speed adjustment control and impact sensor in compliance with European legislation currently in force.

TECHNICAL DATA		BOSS 24V MASTER + BOSS 24V SLAVE
Door lever's max. length	cm	83
Max door surface	m ²	12
Max door width	m	6
Max. door height	m	2,5
Max. torque 1 motor	Nm	350
Operator RPM	rpm	1,8
Adjustable opening time	s	15 ÷ 23
Power supply		230V ~ 50Hz
Motor capacity		24Vdc
Power of 1 motor	W	55
Main line absorption	A	1,2
Normative cycles	n°	∞ - 20s/2s
Daily cycles suggested	n°	36
Service		50%
Actuator weight	kg	9,5 MASTER + 8 SLAVE
Noise	db	<70
Operating temperature	°C	-10 ÷ +55 °C
Protection grade	IP	44

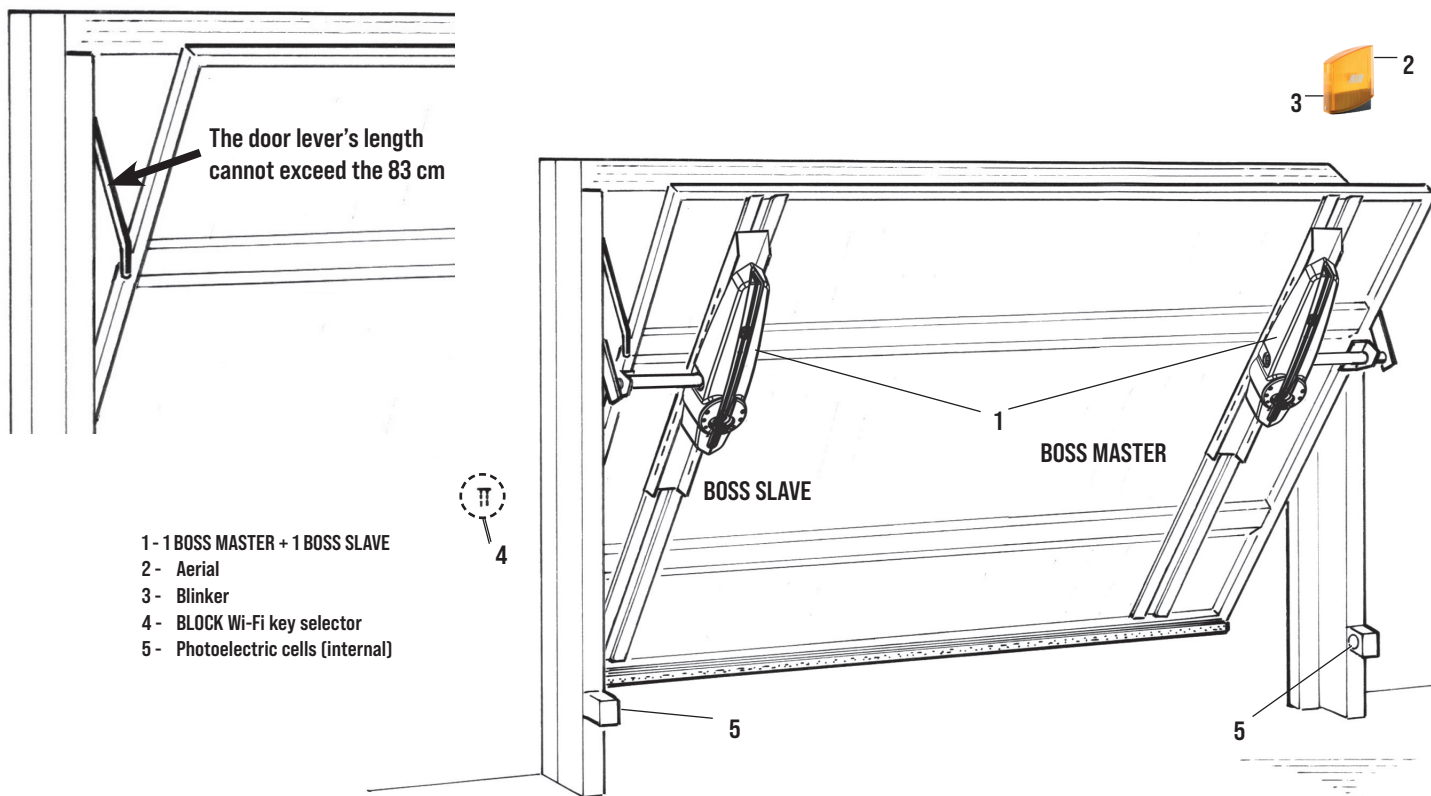

PRE-INSTALLATION CHECK

For doors with a total width up to 6 m, maximum height 2,5 m or a total surface area of 12 square metres and door lever's length with maximum length 83 cm, 2 BOSS (MASTER AA40840 + SLAVE AA40845) device should be used; mounted as shown in Fig. 3, with a PAIR OF STRAIGHT LEVERS code ACG8720 (or a PAIR OF CURVED LEVERS code ACG8722), the accessories for LATERAL TRANSMISSION for 2 operators cod. ACG8715 and 2 SHORT MOUNTING PLATE codes ACG8189 or 2 LONG MOUNTING PLATE codes ACG8188.

- Check that the available space between the moving frame of the door and external frame with counterweights exceeds 15 mm. If so, the STRAIGHT LEVERS can be mounted. Otherwise, mount the CURVED LEVERS if the distance is less than 15 mm, making sure to remain within the assembly parameters described in Fig. 4.
- Check that the up-and-over door slip bearings are not blocked or obstructed and that the counterweight fastening cables are in correct working order.
- Remove, if present, the manual closing lever connected to the locking device.

N.B. It is obligatory to uniform the characteristics of the door to the standards and laws in force. The door can be automatized only if in a good state and if in accordance with EN 12604 standard.

No trapping points must be generated (for example between horizontally pivoted open door and wall).

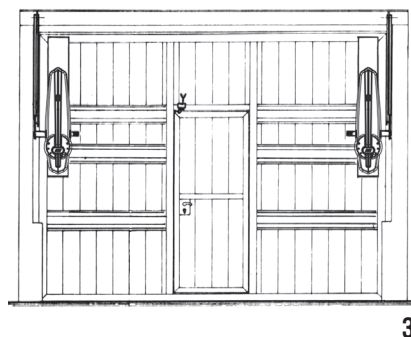

Parts to install according to EN 12453 standard			
COMMAND TYPE	USE OF THE SHUTTER		
	Skilled persons (out of public area*)	Skilled persons (public area)	Not skilled persons
Hold-to-run operation	A	B	Not possible
Impulsive - in sight (e.g. push-button)	C or E	C or E	C and D, or E
impulsive - out of sight (e.g. remote)	C or E	C and D, or E	C and D, or E
automatic	C and D, or E	C and D, or E	C and D, or E

* a typical example are those doors which do not have access to any public way
 A: Hold-to-run operation made by push-button ex: code ACG2013
 B: Hold-to-run operation made by key selector ex: code ACG1010
 C: Adjustable power of the motor or photocells to respect impact forces as indicated in Annex A
 D: Safety strips and/or other additional devices to reduce the probability of contact with the door.
 E: Devices installed in such a way that a person can not be touched by the door.

INSTALLATION OF 2 MOTOR BOSS ON DOORS UP TO 12 m²

LEVER APPLICATION

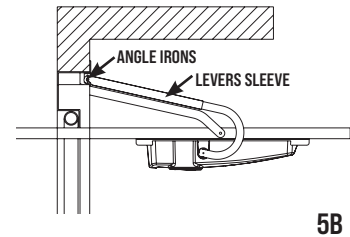
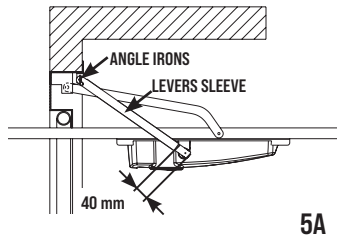
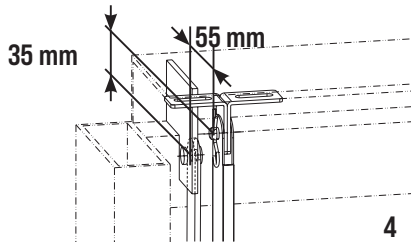

ASSEMBLY OF PAIR OF STRAIGHT LEVERS (code AC68720) BETWEEN MOTOR AND UPPER DOOR FRAME

N.B.: THE PAIR OF STRAIGHT TELESCOPIC LEVERS can be mounted when there is a 15 mm minimum space guaranteed between the moving part of the door and the exterior door frame containing the counterweight.

- Rivets or screws should be used to fix corner parts to the upper frame, in line with measurements shown in Fig. 4: **if at the measurement of 35 mm, one finds the reinforcing plate of the door frame, it is possible to fix the brackets directly above this reinforcing plate even if the measurement will not be maintained.**
- In the event that the up-and-over door is already pre-fitted for automated movement, use the attachments provided. **Do not use the angles provided.**
- Insert the sliding arm sleeve into the angles and secure the pivots and split pins (Fig. 4).
- Make sure that the casing does not touch the up-and-over door movement levers when mounted.

ASSEMBLY OF PAIR OF CURVED LEVERS (code AC68722) BETWEEN MOTOR AND UPPER DOOR FRAME

N.B.: THE PAIR OF CURVED TELESCOPIC LEVERS should be mounted when there is less than the 15 mm minimum space guaranteed between the moving part of the door and the exterior door frame containing the counterweight.

- In the event that the up-and-over door is already pre-fitted for automated movement, use the attachments provided. **Do not use the angles provided.**
- Insert the sliding arm sleeve into the angles and secure the pivots and split pins (Fig. 4).
- Make sure that the casing does not touch the up-and-over door movement levers when mounted.

Note: The length of the sleeve and of the sliding arm must be modified in function of overhead door height. Trim the sleeve and the sliding arm so that the sleeve rests 40 mm from the center of the drawbar pivot pin and the sliding arm avoids contact with the rotating dowels located on the angles (Fig. 5A)

LONG MOUNTING PLATE (FOR NON-AUTOMATED UP-AND-OVER DOORS)

Code AC68188

Position the mounting plate with the upper section (slotted hole to feed electric cable) in top position (Fig. 6).

Fix the mounting spar flush against the upper moving part of the up-and-over door distance of 17 cm from the internal cable of the sheath using 6.3 x 13 self-tapping screws (not included).

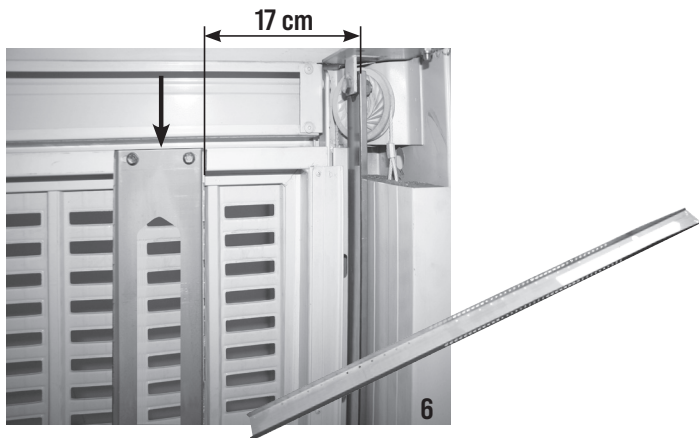

SHORT MOUNTING PLATE (FOR AUTOMATED UP-AND-OVER DOORS)

Code AC68189

Calculate the length, $L = C - 410$ [mm], to which the mounting plate should be vertically fixed (Fig. 7-8).

Position it on the appropriate vertical supports while keeping the upper part (slotted hole to feed electric cable) in a vertical position facing upwards. Fix the mounting plate distance of 17 cm from the internal cable of the sheath using the four feedthrough holes, four 4 metric screws (M6x25) and self-locking nuts (not supplied).

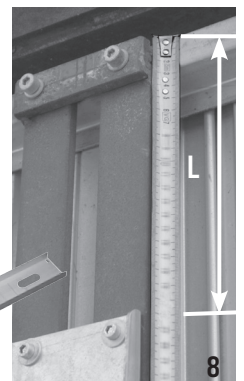
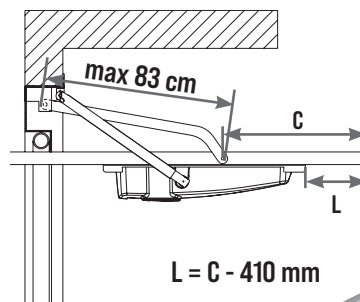

After the assembly's completion, either with the LONG MOUNTING PLATE or with the SHORT MOUNTING PLATE, the reducer's outlet-shaft must be placed in a distance of 80 ± 10 mm from the pivot-axe of the up-and-over door's little arm.

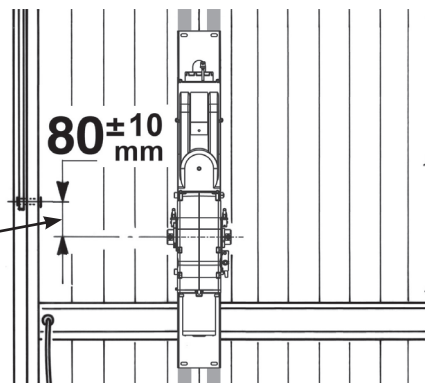

OPERATORS ASSEMBLY

- Fix BOSS to the mounting plate using the screws supplied (Fig. 9-10-11-12).
- Check the balance of the up-and-over door.
If incorrect, and in the event that the doors are not motor-driven, add 9 kg to each counterweight in order to achieve the correct balance.

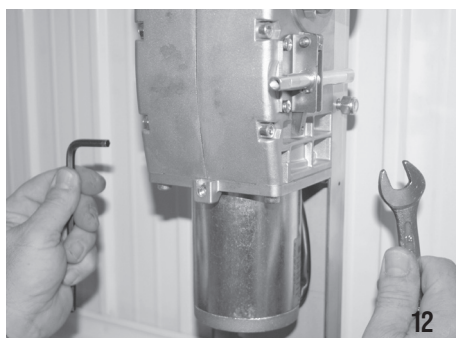
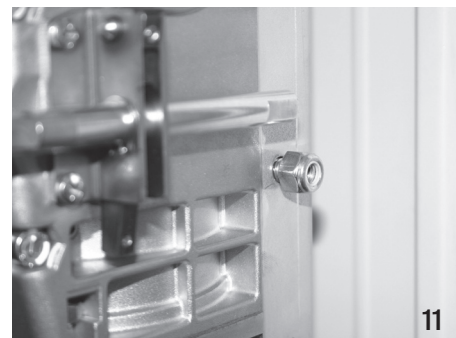
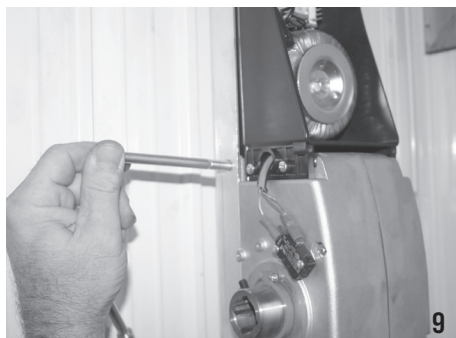

POSITIONING OF THE SQUARE DRIVING SHAFT ON THE OPERATORS

- Insert the square driving shaft into the operator take-off shaft end (Fig. 13).

RE-BALANCING OF THE DOOR

When installing 2 BOSS operator on a door, 9 kg extra each side must be applied on the existing counterweights.

CORNER TRACK BLOCK FIXING - 2 MOTORS

- Insert the bushing with locking pins for both sides of the square driving shaft 20 x 20 (Fig. 14).
- Fix the adjustable support angle bars to the moveable up-and-over door frame in line with the square driving shaft (Fig. 15). **WARNING: fastening screws not supplied.**
- Insert bushings in the supports (Fig. 16), bolt the support structures into place (Fig. 17).
- Check that the STRAIGHT LEVERS (code AC68720) are perfectly perpendicular and do not touch the counterweight casing or moving door parts. The PAIR OF CURVED LEVERS (code AC68722) should be mounted when there is less than the 15 mm minimum space guaranteed between the moving part of the door and the exterior door frame containing the counterweight (while aligned with measurements described in Fig. 4).

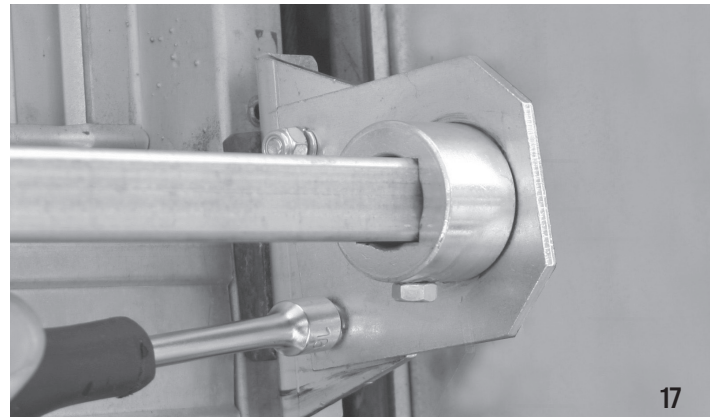
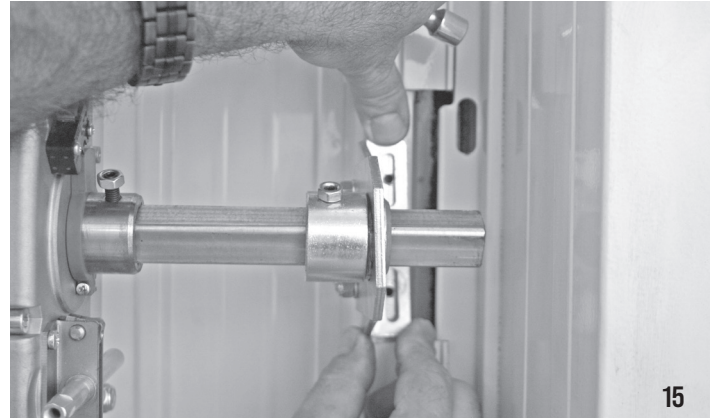
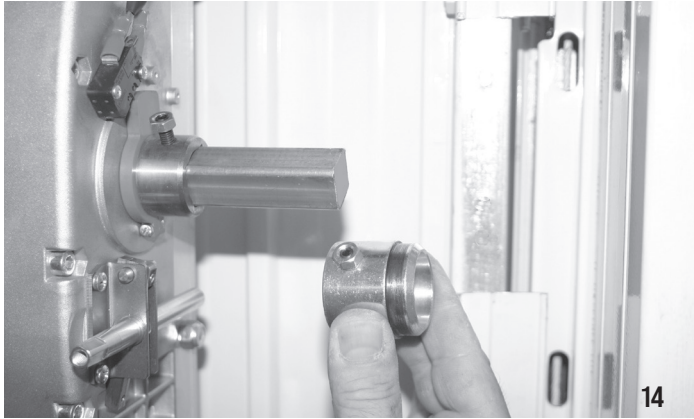

CORNER TRACK BLOCK TUBING AND LEVER FIXING

- Insert the lever into the sleeve and the welded bushing into the square driving shaft (Fig. 18).
- Begin to lock the pins positioned on the track shaft into position (Fig. 19-20) on the centring bush and relative lock nuts (Fig. 21).
- Fix the lever to the tubing tight with locking pin and lock nut (Fig. 22-23).
- With the help of the handles inserted in the relative release mechanism, mechanically release the operators (Fig. 24-25)
- Verify the correct movement of the door and then lock the motors again.
- Lubricate the door's levers and guides.

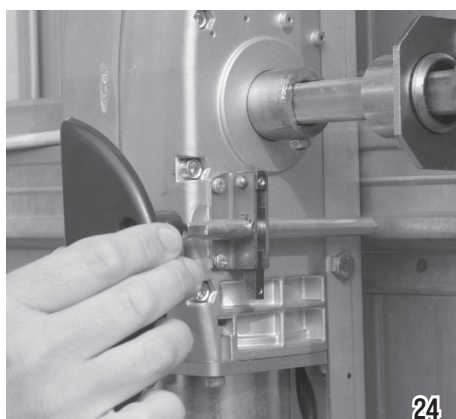
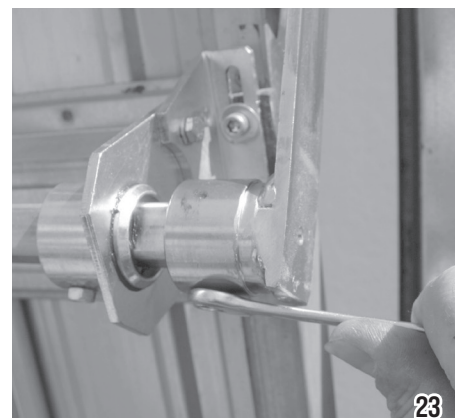
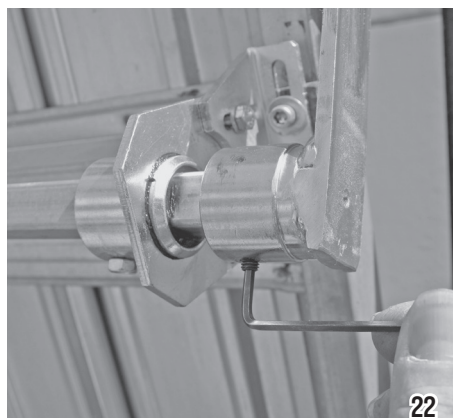
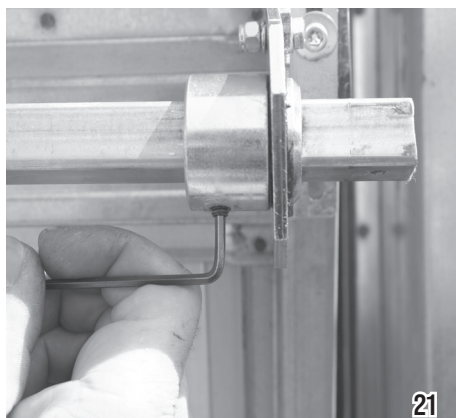
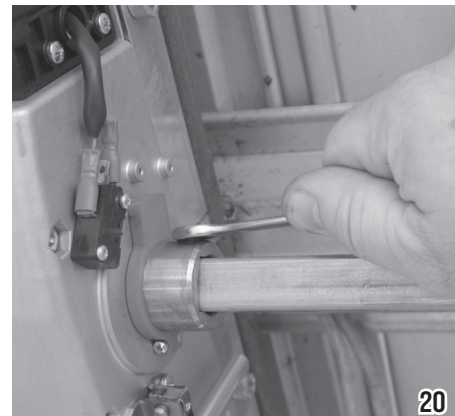
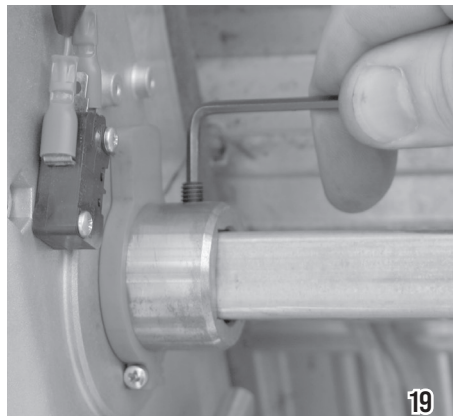

ELECTRICAL CONNECTION

Once you have removed the covers of the control panel boxes both on the Master and on the Slave motors (pict 26), insert the SLAVE control panel onto the MASTER control panel inside the MASTER operator (Fig. 30 - 31) inserting the spacer support in the appropriate hole (Fig. 30). Carry out the electrical connection as shown in Fig. 69 in order to check 'dead man's switch' control to up-and-over door commands.

WARNING: IPX4 can only be guaranteed by mounting the rubber cable fairleads in the electrical switchboard into the relative container holes (Fig. 27) and the rounded slotted wire seal on the cover latch (Fig. 28).

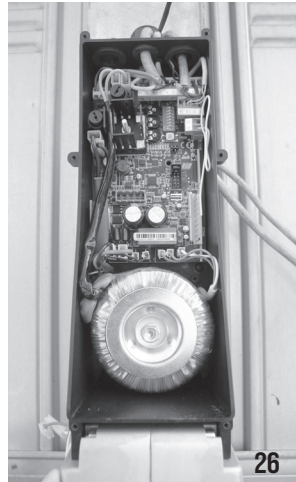

26

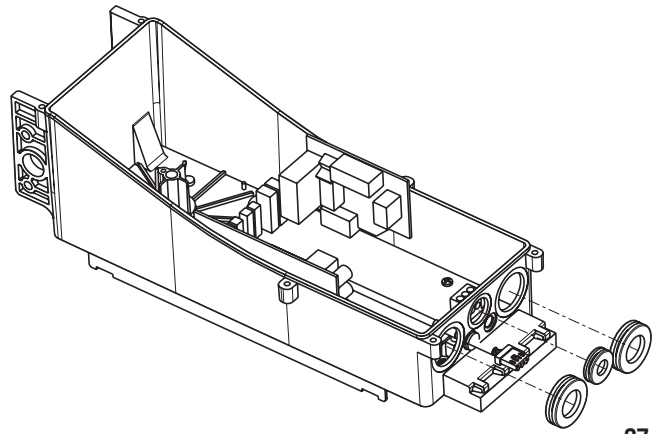

27

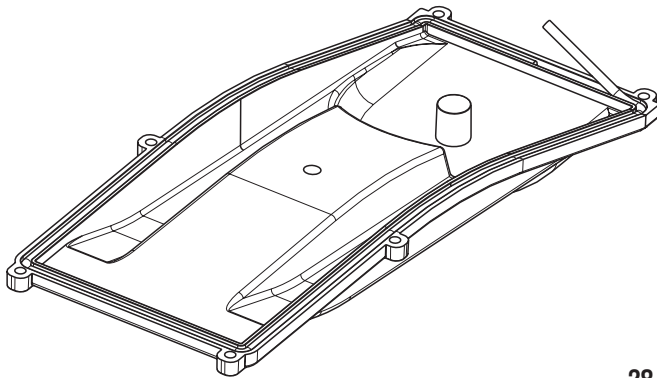

28

ELECTRICAL CABLE FIXING SIDE MASTER OPERATOR

The electrical cable that powers the operator should NOT be fixed to the telescopic lever (Fig. 29).

The cable should be curved in order that it is not subject to twist, tension or tearing while the door is in movement.

Cables exiting the door plate hole should be protected with some form of sheath to avoid their being cut during movement.

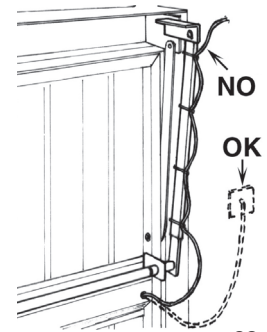

29

LIMIT SWITCHES ADJUSTMENT - MASTER OPERATOR

- Position DIP 8 to ON and press the command button on the electrical switchboard (Fig. 31) to start up-and-over door movement. Release the button once the operation has been carried out. Slacken the holding screw for the green cam and turn until activating the microswitch (Fig. 34).
- Tighten the green cam holding screw (Fig. 35).
- Press the key on the electronic switchboard (Fig. 31) to close the up-and-over door movement. Release the button once the closing operation has been completed. Slacken the holding screw for the red cam and turn until the microswitch is activated (Fig. 37).
- Tighten the red cam holding screw (Fig. 38).
- Carry out a complete opening and closing cycle to check that the cams are positioned perfectly. Correct positions if required.
- Turn DIP8 to OFF.

Refer to the section ELECTRICAL CONNECTIONS for connection to auxiliary units and switchboard functions.

Close the electrical box with the appropriate cover using the 6 screws provided.

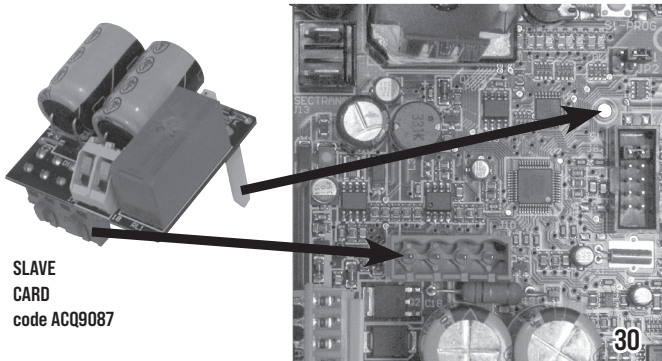

SLAVE CARD
code ACQ9087

30

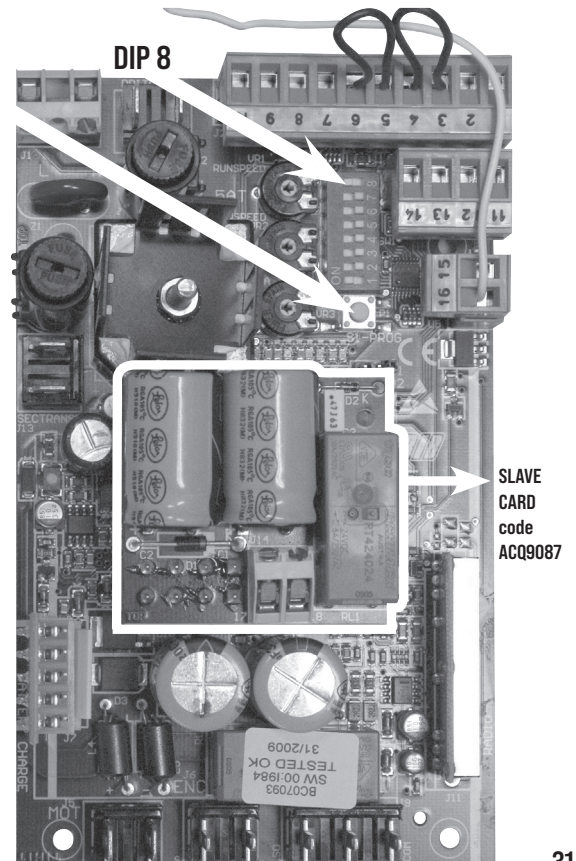

SLAVE CARD
code ACQ9087

31

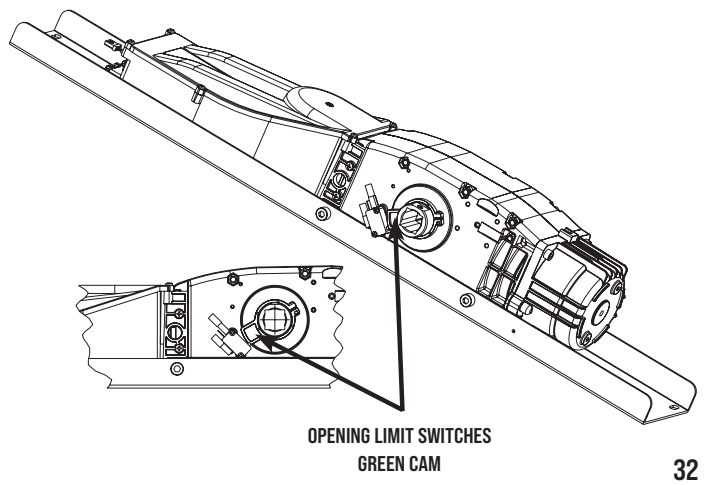
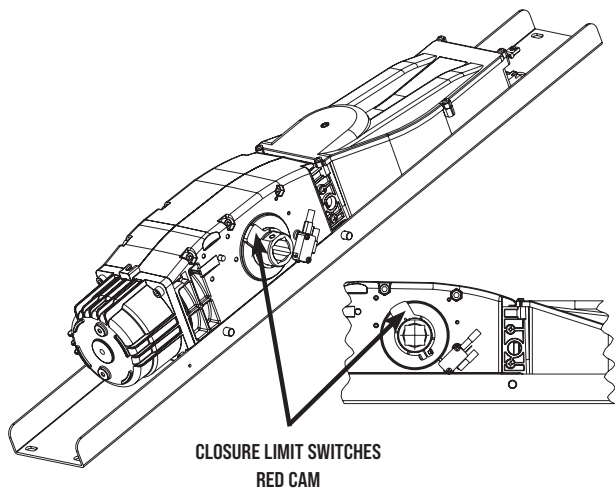

32

OPENING LIMIT SWITCHES ADJUSTMENT

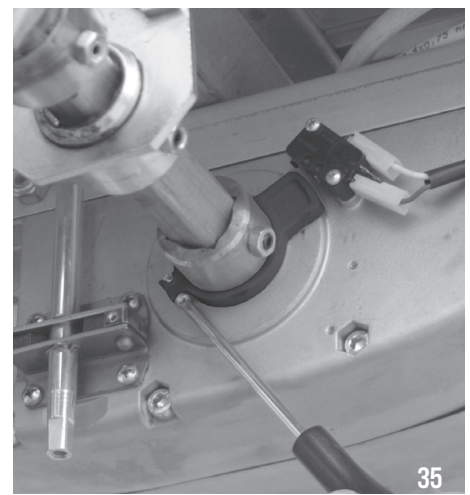
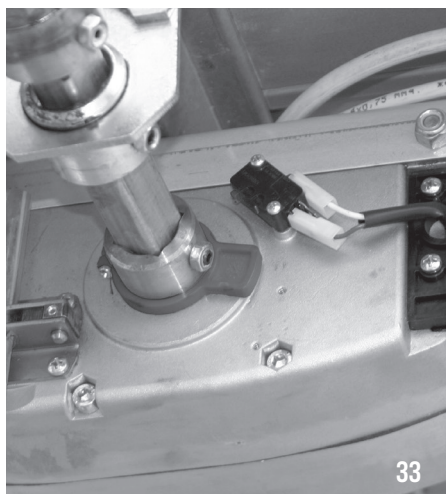

CLOSURE LIMIT SWITCHES ADJUSTMENT

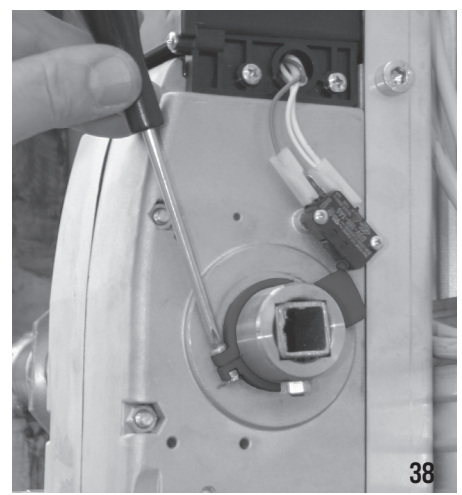
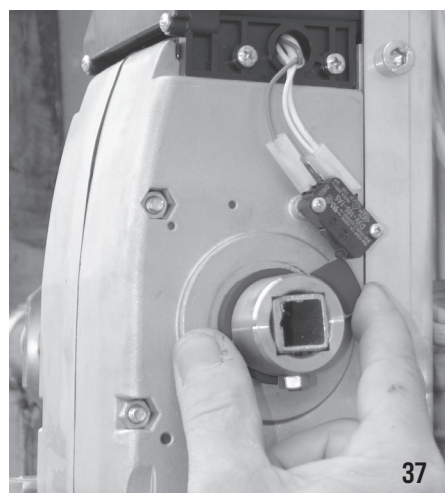
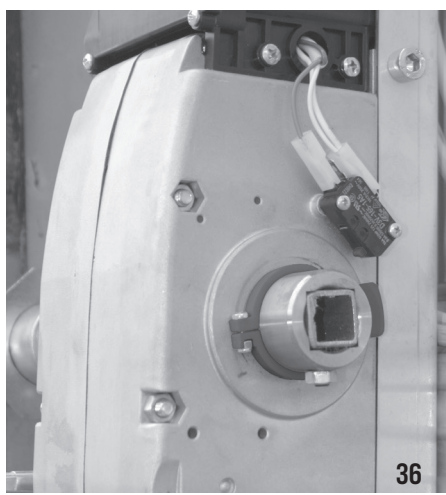

CASING MOUNTING

- Mount the fixed handle (without release warning) on the casing using the screws, bolt and washer supplied, inserting them on the opposite side to the release device (Fig. 39).
 - Apply the cap on the side of the operator where the driving shaft if not sticking out (pic 46).
 - Connect the illuminator unit connector to the cable leading from the electrical switchboard (Fig. 40 and 41).
 - Insert the casing on the reducer, making sure to position it on the mounting plate in the appropriate position and centre the release spar with the predrilled holes on the casing. Fasten the casing to the motor with the screws supplied (Fig. 43 and 44) and then fix the release device handle (Fig. 45) to the motor release device spar.
 - Apply the lateral cap.
- The operator is now installed and ready to carry out tutoring programme operations (refer to PROGRAMMING section).

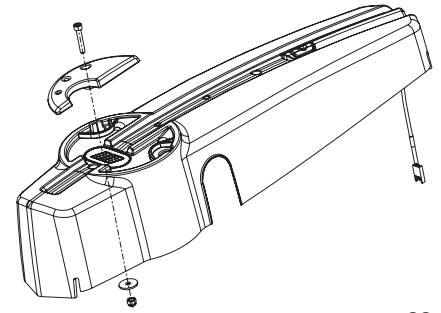

39



40



41



42



43



44

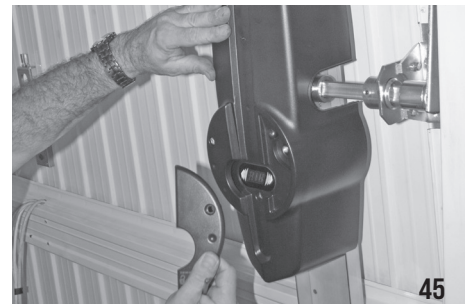

45

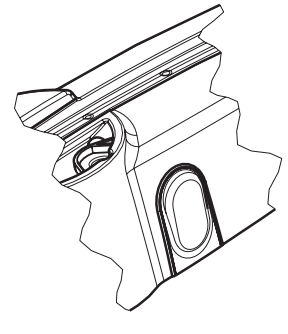
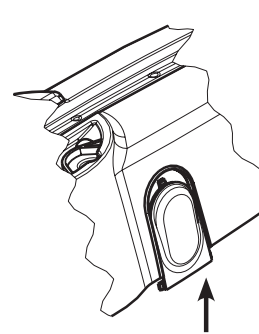
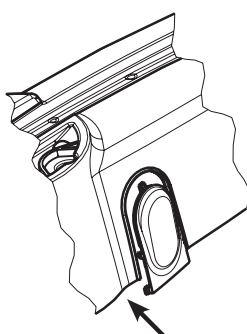
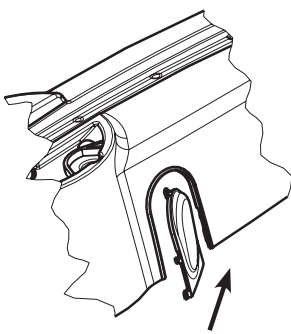

46

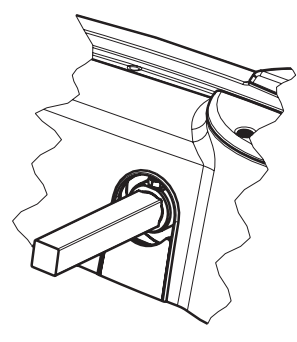
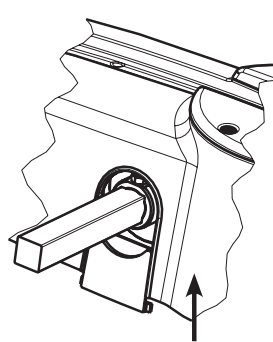
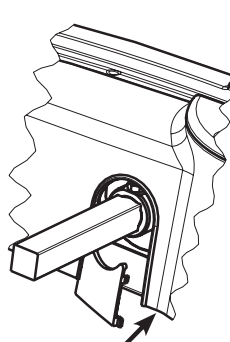
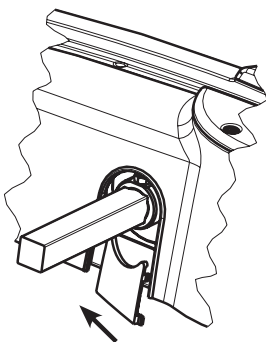

47

INTERNAL RELEASE DEVICE HANDLE

BOSS is generally supplied with a manual release device handle that can be operated from inside the premises (Fig. 48).

In the event of power failure turn both the handles of the operators.
This will unlock the reducers and allow the door to be opened manually.
Turn the handles back to their original position in order to block the reducer.

In order to carry out the manual movement of the spar safely, it is important to check that:

- The door is supplied with suitable handles.
- Handles are positioned in such a way so as not to create hazard points during their use.
- The manual effort required to move the door should not exceed 225N for doors installed for private use and 390N for doors for commercial or industrial use (parameters set by item 5.4.5 of EN 12453 standard).

WARNING: The release mechanism may cause the door to move in an unpredictable fashion if the door has not been correctly centred and balanced. In such cases, it is necessary to carry out the necessary balancing operations to the up-and-over doors.



48



49

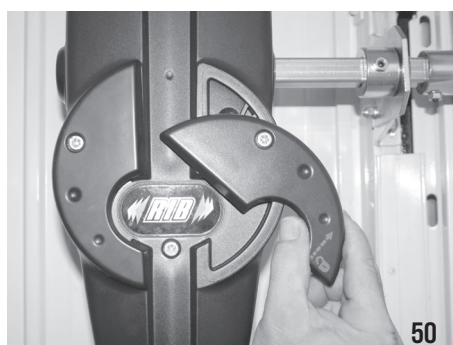

50



51

CABLE UNLOCKING RELEASE

With such type of release system, in case of black outs, it is possible to release the motors from the outside. It is therefore advisable, when the garage door is the only possible way of access.

The release device (code ACG8734) is mounted on the existing locking apparatus installed on the up-and-over door.

ATTENTION: in case of 2 locks on the door, fit for each lock unlocking release ACG8730.

For the assembly see the accessory specific instructions.

Follow the instructions described from Fig. 53 to 64.

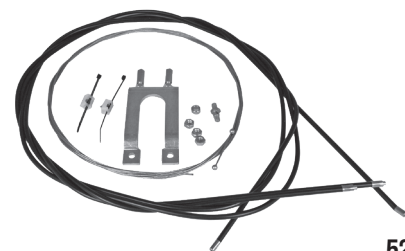

52

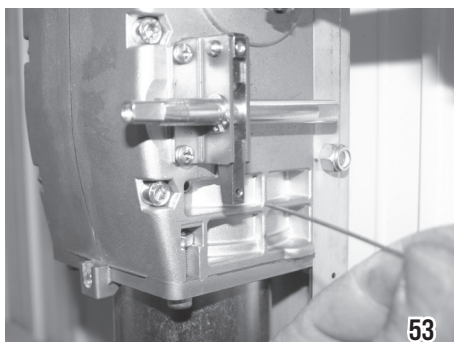

53



54

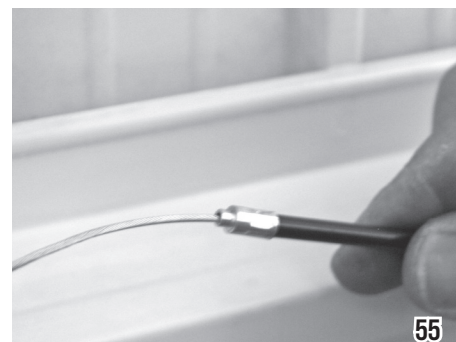

55



56

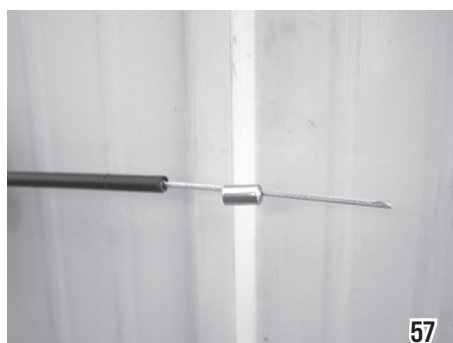

57



58

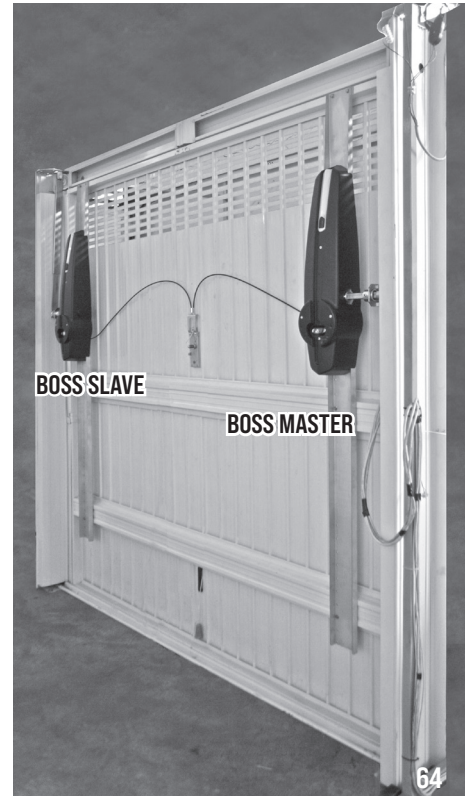
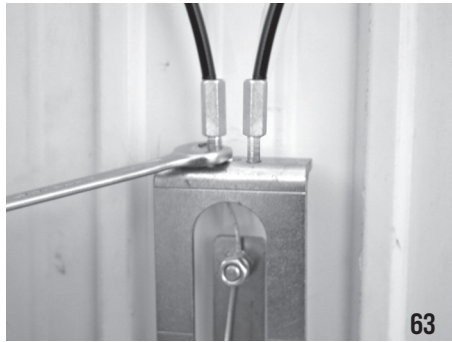
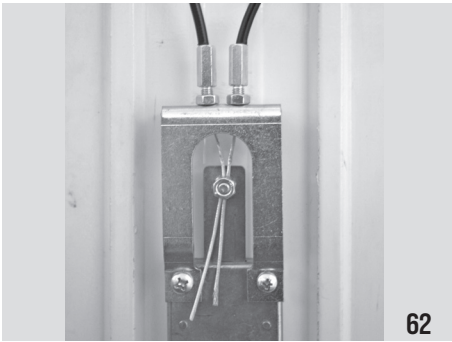
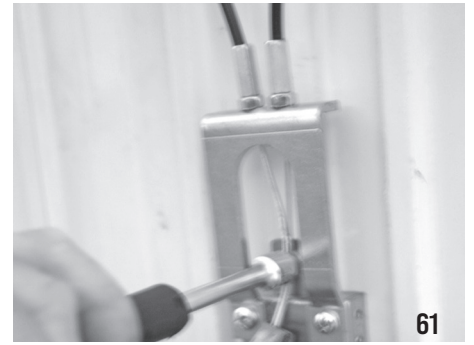

ALLEN KEY LOCK UNLOCKING RELEASE

It is also possible to release the locking device from the outside using auxiliary device code ACG8732 and customised key.

For the assembly see the accessory specific instructions.

Follow the simple operations described below in order to carry out unlocking operations:

- Remove the lock barrel with the appropriate key (Pic. 66).

- Insert an allen wrench (no. 6) in the hole of the plate as far as the release device bushing (Pic. 67).
- Turn the hexagonal key in the direction indicated on the sticker on the up-and-over door until the operator unlocking device is activated (Pic. 68).
- In order to lock the reducer, turn the hexagonal key in the direction indicated on the sticker on the up-and-over door (Pic. 68).



65



66



67

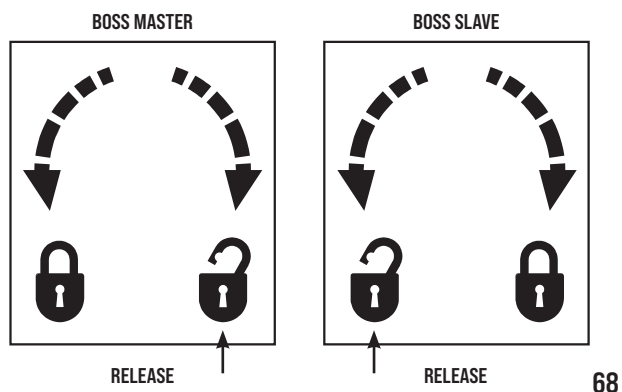

68

ATTENTION!

The coupling of the releases with closed door doesn't guarantee the total closing of the door. It will partially remain opened until an electrical movement. The corrected closing will only happen with electrical closing completed.

MAINTENANCE

To be undertaken only by specialized staff after disconnecting power supply.

Grease the fulcrums, the counterweight channels, the telescopic levers and carry out the necessary impacts force check as for EN 12453 once a year.

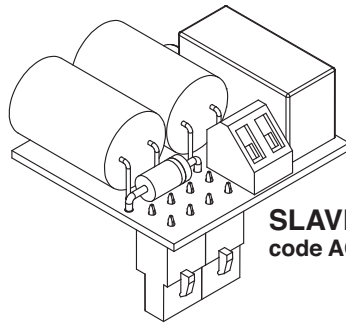

SLAVE CARD
code ACQ9087

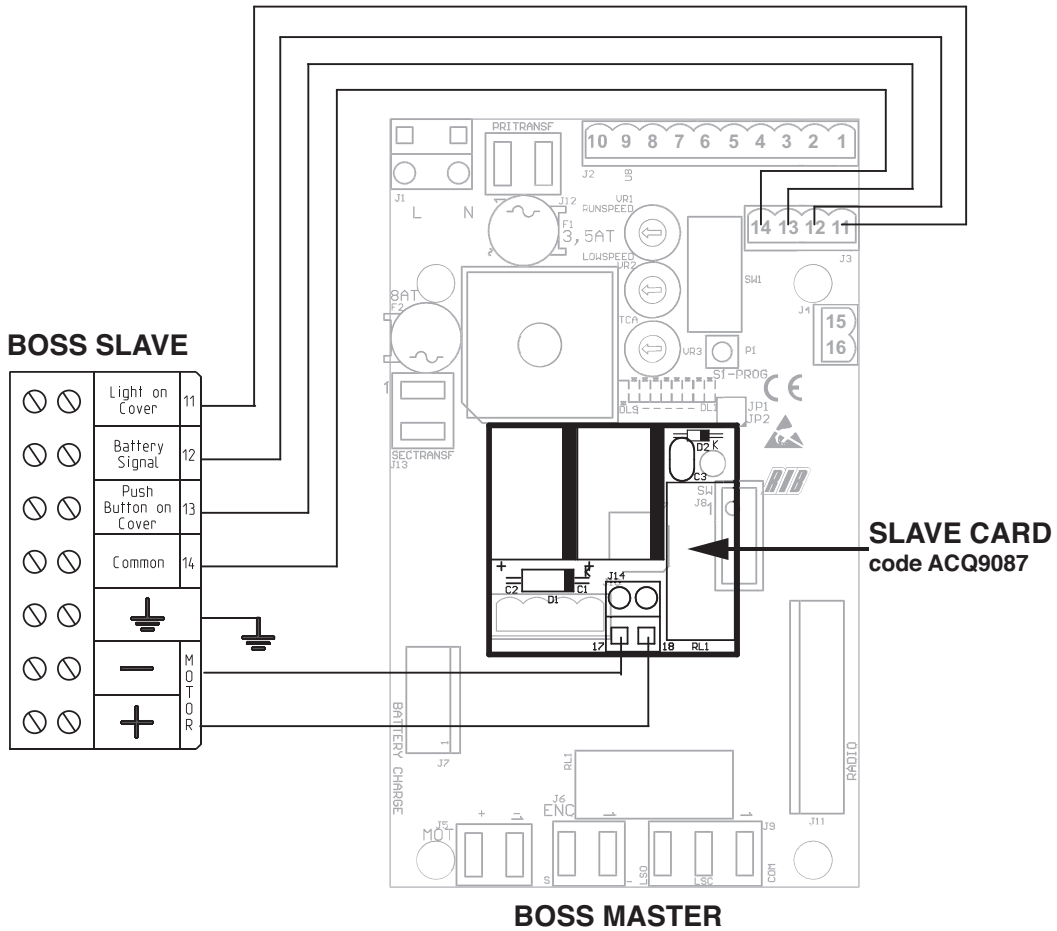

BOSS SLAVE

⊖ ⊖	Light on Cover	11
⊖ ⊖	Battery Signal	12
⊖ ⊖	Push Button on Cover	13
⊖ ⊖	Common	14
⊖ ⊖	⊕	MOTOR
⊖ ⊖	⊖	
⊖ ⊖	+	

SLAVE CARD
code ACQ9087

BOSS MASTER

WIRING CONNECTIONS BETWEEN MASTER AND SLAVE MOTORS

SLAVE card allows users to operate a second motor on up-and-over doors with a surface area exceeding 9 m². Switch off the power supply to the system and insert the slave board into the J10 connector. The board will be automatically configured once the system is switched back on preset for 2 motors.

Connect the 4 wires (min. diam. 0,5 mm²) from the contacts 11-12-13-14 of the Master control panel to the contacts 11-12-13-14 on the SLAVE control panel.

Connect the motor wires (min. diam. 1,5 mm²) from the contacts 17-18 of the SLAVE control panel to the contacts - and + available in the box on the motor slave.

PEDESTRIAN SECURITY (terminals 5 ad 6)

In the event that the main up-and over-doors are also equipped with pedestrian access, connect a microswitch (N.C. closed pedestrian access door) to signal to the control panel that the pedestrian door is open or closed. Connection should be carried out using terminals 5 and 6 (where no safety strips are connected), or, where present, in safety strip contact series. To ensure correct system operations, the DL3 LED lamp should be illuminated, signalling that the pedestrian door is closed correctly. If the led DL3 is OFF, the movement of the garage door will not be possible, because the pedestrian door is open.

NOTE: Create a jumper if terminals 5 and 6 are not used by safety strips or other devices.

ACCESSORIES

For the connections and the technical data of the optional equipments follow the relevant handbooks.

CABLE UNLOCKING RELEASE

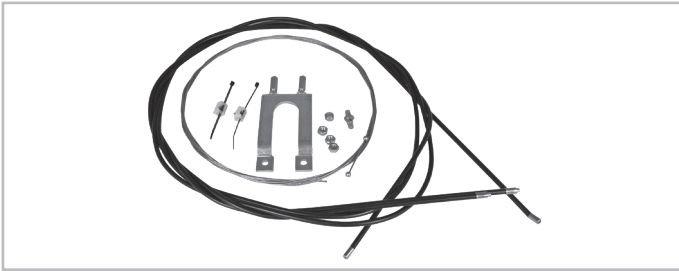

code ACG8734

ALLEN KEY LOCK UNLOCKING RELEASE



code ACG8732

BATTERY CHARGE CARD BOSS 24V

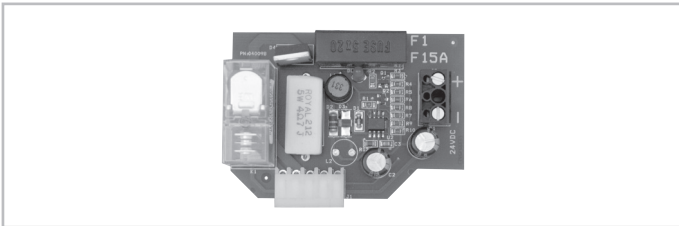

code ACG4663

BOX WITH BATTERIES



code ACG2246

FIT SLIM



PAIR OF PHOTOCELLS FOR THE WALL-INSTALLATION
PAIR OF COLUMNS FOR FIT SLIM
SYNCR0 TRANSMITTER TX SLIM SYNCR0

code ACG8032B
code ACG8065
code ACG8029B

PHOTOCELLS NOVA WIRELESS



empty batteries warning - range 30 m - more than 3 years batteries life

BATTERIES AA 4 x 1,5V

code ACG8047
code ACG9519

RADIO TRANSMITTER SUN



SUN 2CH
SUN CLONE 2CH

code ACG6052
code ACG6056

SUN 4CH
SUN CLONE 4CH

code ACG6054
code ACG6058

SAIL

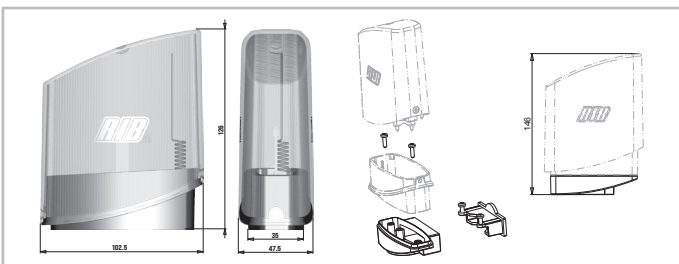

SAIL orange with built-in flashing board
SAIL white with built-in flashing board
SAIL LATERAL SUPPORT

code ACG7072
code ACG7078
code ACG8054

S18



S18 to embed (NO+NO)
S18 to wall (NO+NO)

code ACG1054
code ACG1056

S18 to embed (NO+NC)
S18 to wall (NO+NC)

code ACG1054S
code ACG1056S

NOTES



BOSS 24V SLAVE

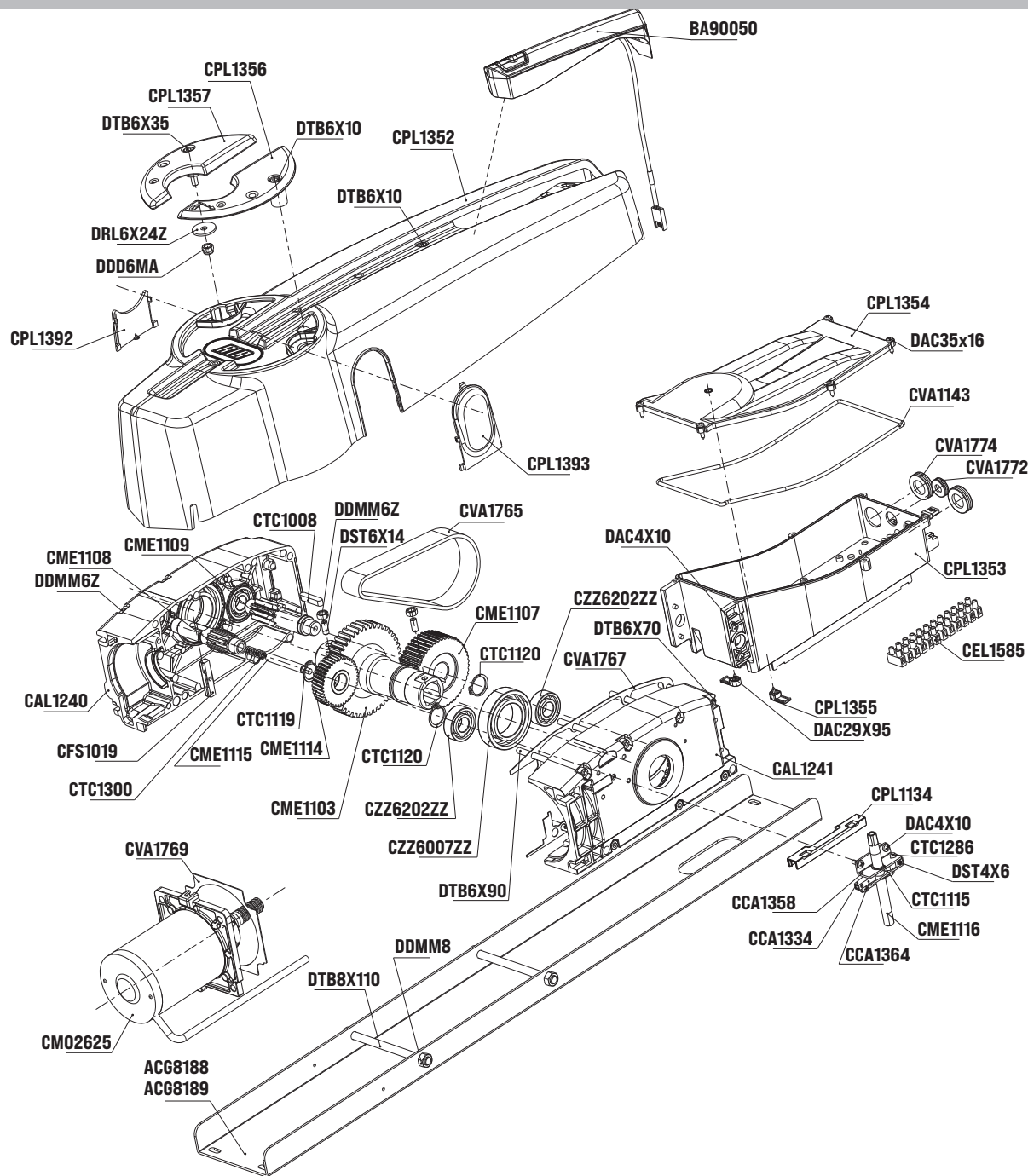

Codice	Denominazione Particolare	Codice	Denominazione Particolare	Codice	Denominazione Particolare
BA90050	Gr.illuminatore BOSS	CPL1352	Carter BOSS	CVA1773	Pass. gomma Aperto 3818 BOSS
CAL1240	Semiguscio Sx BOSS	CPL1353	Contenitore Q.e. BOSS	CVA1774	Pass. gomma C/Membrana Dg16
CAL1241	Semiguscio Dx BOSS	CPL1354	Coperchio Conten. Qe BOSS	CVA1775	Pass. gomma Aperto 843 BOSS
CCA1334	Leva Sblocco BOSS	CPL1355	Tappi Ferma Cavi BOSS	CVA1916	Adesivo Ovale Rib BOSS
CCA1358	Staffa Leva Sblocco Dx BOSS	CPL1356	Manopola Sblocco Dx BOSS	CVA1917	Adesivo Attenzione BOSS
CCA1359	Levetta Sblocco Tirante BOSS	CPL1357	Manopola Sblocco Sx BOSS	CZZ6007ZZ	Cusc. 6007zz
CCA1364	Staffa Leva Sblocco Sx BOSS	CPL1392	Tappo Carter Passante BOSS	CZZ6202ZZ	Cusc. 6202zz 15x35x11
CEL1129	Mors. Mamm.2 P.431/2 Lp	CPL1393	Tappo Carter Cieco BOSS	DAC29X95	Vite Aut. Tc Cr 2 9x9 5 Zinca
CEL1574	Cavo Coll.led/puls.24V Femmina	CTC1008	Chiavetta 6 6 30	DAC35X16	Vite Aut.tc.cr. 3.5x16 Din 798
CEL1585	Mors. Mamm. 12 poli	CTC1119	Seeger E17	DAC4X10	Vite Trilob. Tcr 4x10 Uni8112
CEL1590	Microswitch Puls.omr.v-161.1a5	CTC1120	Seeger E20	DAS35X13	Vite Aut.ts.cr. 3.5x13 Zincata
CFS1019	Linguetta Di Sblocco BOSS	CTC1286	Spina Cil.6x16	DDMM6Z	Dado 6ma Medio Uni 5588
CME1103	Albero Traino Tubo Pass. BOSS	CTC1300	Molla Sblocco BOSS	DRL6X24I	Rond. Piana 6x24 Inox (Poi Zin)
CME1107	Puleggia Z48 BOSS	CTC1607	Anello Or 3137	DST4X6	Grano M4x6 Zinc. P/con 5927
CME1108	Pignone C/dent.cinghia BOSS	CVA1098	Grasso Bechem Rhus 550	DST6X6I	Grano M6x6 Piano Inox Uni 5923
CME1109	Pignone 3 Riduz. BOSS	CVA1143	Guarnizione Coperc. D3 5 LO 67	DTB6X10Z	Vite Tcei M6x10 Uni 5931 Zinc
CME1114	Corona Sblocco Z=40 M1 25 BOSS	CVA1765	Cinghia Dentata 400 Rpp5 25+	DTB6X30	Vite Tcei 6x30 Zinc Uni5931
CME1115	Perno Sblocco BOSS	CVA1767	Guarnizione Gusci BOSS	DTB6X35	Vite Tcei 6x35 Zinc.uni 5931
CME1116	Asta Maniglia BOSS	CVA1769	Guarnizione Motore BOSS	DTB6X70Z	Vite Tcei M6x70 Uni 5931 Zinc
CMO2625	Motore 24Vdc+encoder BOSS	CVA1771	Pass. gomma Aperto 5084 BOSS	DTB6X90Z	Vite Tcei M6x90 Uni 5931 Zinc
CPL1134	Guida Cavi Motore BOSS	CVA1772	Pass. gomma C/Membrana Dg9		

Dichiarazione di incorporazione per le quasi-macchine - Direttiva Macchine 2006/42/CE, Allegato II., B
Déclaration d'incorporation pour les quasi-machines - Directive Machines 2006/42/CE, Annexe II, B
Declaration of incorporation for partly completed machinery - Machinery Directive 2006/42/EC, Annex II., B

R.I.B. S.r.l. - Via Matteotti, 162 - 25014 Castenedolo - Brescia - Italy
 Tel. ++39.030.2135811 - www.ribind.it - ribind@ribind.it

Apparecchio modello : Modèle d'appareil : Apparatus model : BOSS 24V SLAVE	Oggetto della dichiarazione : Objet de la déclaration : Object of the declaration : 		
--	--	--	--

I seguenti requisiti essenziali della Direttiva Macchine (2006/42/CE) sono applicati e rispettati:

- La documentazione tecnica pertinente è stata compilata in conformità alla parte B dell'allegato VII; tale documentazione, o parti di essa, sarà trasmessa per posta o per via elettronica, in risposta ad una richiesta motivata da parte delle autorità nazionali competenti.
- Questa quasi-macchina è conforme alle disposizioni delle seguenti altre direttive CE: **Direttive 2014/30/UE e 2014/35/UE.**
- Sono stati applicati e rispettati tutti i requisiti essenziali pertinenti di cui all'allegato I della direttiva UE 2006/42/CE mediante il rispetto delle norme armonizzate applicate che conferiscono presunzione di conformità ai requisiti essenziali specifici delle Direttive applicabili da esse coperti.

AVVERTENZA: Altri requisiti e altre Direttive UE possono essere applicabili ai prodotti oggetto di questa dichiarazione.

Les exigences essentielles suivantes de la Directive Machines (2006/42/CE) sont appliquées et satisfaites:

- La documentation technique pertinente est constituée conformément à la partie B de l'annexe VII; ces documents, ou des parties de celui-ci, seront envoyés par la poste ou par voie électronique, en réponse à une demande motivée des autorités nationales compétentes.
- Cette quasi-machine est en conformité avec les dispositions des autres directives CE suivantes: **Directives 2014/30/UE et 2014/35/UE**
- Les exigences essentielles pertinentes indiquées dans l'annexe I de la Directive UE 2006/42/CE ont été appliquées, au moyen du respect des normes harmonisées donnant présomption de

conformité aux exigences essentielles pertinentes spécifiques des Directives Européennes, couvertes par de telles normes ou parties de celles-ci.

ATTENTION: On peut appliquer d'autres exigences et d'autres Directives Européennes aux produits couverts par cette déclaration.

The following essential requirements of the Machinery Directive (2006/42/EC) are abided by and applied:

- The relevant technical documentation is compiled in accordance with Part B of Annex VII; such documentation, or parts of it, will be sent by post or by electronic means, in response to a motivated request received from the qualified national authorities.
- This almost complete-machinery is conformed with the provisions of these others EC directives: **Directives 2014/30/EU and 2014/35/EU.**
- All relevant essential requirements as given in Annex I of the EU Directive 2006/42/EC have been applied to the product. Compliance with the cited harmonized standards provides presumption of conformity with the specified essential requirements of the Directive covered by those Standards or parts thereof.

WARNING: Other requirements and other EU Directives may be applicable to the products falling within the scope of this Declaration

L'oggetto della dichiarazione di cui sopra è conforme alla pertinente normativa di armonizzazione dell'Unione:
 L'objet de la déclaration décrit ci-dessus est en conformité avec la législation d'harmonisation de l'Union:
 The object of the declaration described above is in conformity with the relevant Union harmonisation legislation:

EN 12635:2009
 EN 55014-1:2023
 EN 55014-2:2024

EN 60335-1/A16:2024
 EN 60335-2-95:2023
 EN 60335-2-103:2023

EN 61000-3-2/A2:2024
 EN 61000-3-3/A2:2024
 EN 61000-6-1:2019

EN 61000-6-2:2019
 EN 61000-6-3:2023
 EN 61000-6-4:2022

- Il presente prodotto non può funzionare in modo indipendente ed è destinato ad essere incorporato in un impianto costituito da ulteriori elementi. Rientra perciò nell'Art. 6 paragrafo 2 della Direttiva 2006/42/CE (Macchine) e successive modifiche, per cui segnaliamo il divieto di messa in servizio prima che l'impianto sia stato dichiarato conforme alle disposizioni della Direttiva.
- Le présent dispositif ne peut fonctionner de manière indépendante, étant prévu pour être intégré à une installation constituée d'autres éléments. Aussi rentre-t-il dans le champ d'application de l'art. 6, paragraphe 2 de la Directive machines 2006/42/CEE et de ses modifications successives. Sa mise en service est interdite avant que l'installation ait été déclarée conforme aux dispositions prévues par la Directive.
- This product can not work alone and was designed to be fitted into a system made up of various other elements. Hence, it falls within Article 6, Paragraph 2 of the EC-Directive 2006/42 (Machines) and following modifications, to which respect we point out the ban on its putting into service before being found compliant with what is provided by the Directive.

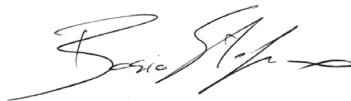

[Bosio Stefano - Legal Representative]

Castenedolo, 15-03-2025

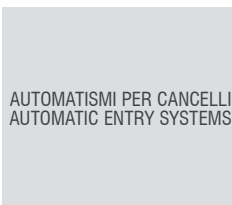

**COMPANY WITH
 QUALITY SYSTEM
 CERTIFIED BY DNV
 ISO 9001**