

K800 - K1100 - K1400 - K2200

مع / with L1-CRX

CE UK
CA

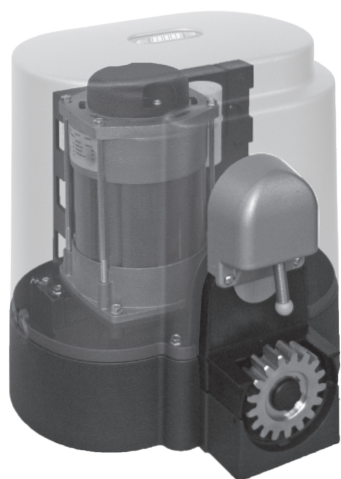

K FCE



K FCM



رسومات فنية للمشروعات

Technical drawings for projects



See page 40



عامل Operator		مزود الطاقة Power Supply	ماكس بوابة الوزن Max gate weight	ماكس التوجه Max Thrust	الانفعال الأقصى Max torque	مع جهاز استقبال لاسلكي with radio receiver	الشفرة Code
K800	FCE	230V 50/60Hz	800 kg / 1766 lbs	60 kg / 132 lbs	20,4 Nm	AA31130	AD31130
	FCM					AA31136	AD31136
K1100	FCE		1100 kg / 2425 lbs	73,5 kg / 162 lbs	25 Nm	AA31128	AD31128
	FCM					AA31129	AD31129
K1400	FCE		1400 kg / 3090 lbs	79 kg / 173,8 lbs	27 Nm	AA31140	AD31140
	FCM					AA31142	AD31142
K2200	FCE		2200 kg / 4856 lbs	115 kg / 253 lbs	39 Nm	AA31150	AD31150
	FCM					AA31152	AD31152

**ATTENTION - FOR THE SAFETY OF PEOPLE IT IS IMPORTANT TO FOLLOW ALL THE INSTRUCTIONS
KEEP THESE INSTRUCTIONS WITH CARE**

- 1° - If it is not forecast in the electric gearcase, install a switch of magneto thermic type upstream, (omni polar with minimum opening of the contacts of 3 mm) with a check of conformity to the international standards. Such device must be protected against the accidental lockup (for example by installing inside a locked board).
- 2° - For the section and the type of the cables RIB advises to use a cable of H05RN-F type with 1,5 sqmm minimum section and, however, to keep to the IEC 364 and installation standards in force in your country.
- 3° - Positioning of a possible couple of photoelectric cells: the radius of the photoelectric cells must be at a height of no more than 70 cm from the ground and at a distance not superior to 20 cm from the motion plane of the door. Their correct working must be verified at the end of the installation in accordance with the point D.3.2 of the EN 12453
- 4° - To fulfill the limits set by EN 12453, and in case the peak force exceeds the normative limit of 400 N it is necessary to have recourse to the active presence survey on the whole height of the door (up to max 2,5 m) - The photoelectric cells, in this case, must be applied in accordance with the point D.4.1 of the EN 12453.

N.B.: The earthing of the system is obligatory.

The data described in this handbook are purely a guide.

RIB reserves the right to change them in any moment.

Carry out the system in the respect of the standards and laws in force.

**IMPORTANT SAFETY INSTRUCTIONS FOR THE INSTALLATION
ATTENTION - THE INCORRECT INSTALLATION CAN CAUSE SERIOUS DAMAGES
FOLLOW ALL INSTALLATION INSTRUCTIONS**

- 1° - This handbook is exclusively addressed to the specialized personnel who knows the constructive criteria and the protection devices against accidents for motorized gates, doors and main doors (follow the standards and the laws in force).
- 2° - The installer will have to issue a handbook to the final user in accordance with the EN 12635.
- 3° - Before proceeding with the installation, the installer must forecast the risks analysis of the final automatized closing and the safety of the identified dangerous points (Following the standards EN 12453).
- 4° - Before installing the motion motor, the installer must verify that the gate is in good mechanical conditions and that it adequately opens and closes.
- 5° - The installer must install the member for the manual release at a height inferior to 1,8 m.
- 6° - The installer will have to remove possible impediments to the motorized motion of the gate (eg. door bolts, sliding bolts, door locks etc.)
- 7° - The installer will permanently have to put the tags warning against the deflection on a very visible point or near possible fixed controls.
- 8° - The wiring harness of the different electric components external to the operator (for example photoelectric cells, flashlights etc.) must be carried out according to the EN 60204-1.
- 9° - The possible assembly of a keyboard for the manual control of the movement must be done by positioning the keyboard so that the person operating it does not find himself in a dangerous position; moreover, the risk of accidental activation of the buttons must be reduced.
- 10° - Keep the automatism controls (push-button panel, remote control etc.) out of the children way. Command device for operating the motor (a switch manually closed) should be placed in area visible from the guided site and far from moving parts. It should be placed at least at 1,5 m height.
- 11° - this appliance can be used by children aged from 8 years and above and persons with reduced physical, sensory or mental capabilities or lack of experience and knowledge if they have been given supervision or instruction concerning use of the appliance in a safe way and understand the hazards involved
- 12° - children shall not play with the appliance
- 13° - cleaning and user maintenance shall not be made by children without supervision
- 14° - do not allow children to play with fixed controls. Keep remote controls away from children
- 15° - Fixed command devices should be installed in a well visible way.
- 16° - Before carrying out any installation, regulation or maintenance operation of the system, take OFF the voltage by operating on the special magneto thermic switch connected upstream.
- 17° - At the end of the installation, the installer will have to make sure that the parts of the door do not encumber streets or public sidewalks.

THE RIB COMPANY DOES NOT ACCEPT ANY RESPONSIBILITY for possible damages caused by the non observance during the installation of the safety standards and of the laws in force at present.

تنبيه - للسلامة الناس من المهم أن اتباع جميع التعليمات

احفظ بهذه التعليمات مع كبر

- 1° - إذا لم يتم التنبؤ بها في علبة التروس الكهربائية، وتثبيت التبديل من نوع مغناطيسي حراري المنبع، (اومني القطبية مع الحد الأدنى من افتتاح اتصالات 3 مم) مع الاختيار المطابقة للمعايير الدولية . هذا الجهاز يجب أن تكون محمية ضد سجن عرضي (على سبيل المثال عن طريق تثبيت لوحة داخل مؤمن) .
- 2° - لا قسم ونوع من النماذج لاستخدام الكابلات RIB برفية نوع H05RN-F مع 1.5 sqmm الحد الأدنى و القسم ، ومع ذلك ، للحفاظ على IEC 364 و معايير التركيب المعمول بها في بلدك.
- 3° - وضعية بضع ممكن من الخلايا الكهروضوئية : ؟ يجب أن يكون نصف قطر الخلايا الكهروضوئية على ارتفاع لا يزيد عن 70 سم من الأرض و على مسافة لا تتفوق على 20 سم من الطائرة الحركة من الباب. يجب التحقق من هذه العمل الصحيح في نهاية التثبيت وفقا لنقطة D.3.2 من EN 12453
- 4° - للوفاء حدود التي وضعتها EN 12453 ، وفي حالة القوة الذروة يتجاوز الحد المعياري ل 400 N فمن الضروري أن يكون الجوء للمسح جود نشط على ارتفاع كاملة من الباب (إلى حد أقصى 2,5 م) - الخلايا الكهروضوئية، في هذه الحالة، يجب أن تطبق وفقا لنقطة D.4.1 من EN 12453

إلا مع الأدوات.

ملحوظة : إن التأريض من النظام واجبة.

البيانات الموضحة في هذا الكتيب هي محض دليل.

تحتفظ RIB الحق في تغييرها في أي لحظة.

تنفيذ نظام في احترام المعايير والقوانين المعمول بها.

تعليمات السلامة هام لتركيب

تحذير - لا التثبيت الصحيح يمكن أن يسبب أضرار خطيرة

اتباع جميع تعليمات التثبيت

- 1° - يتم تناول هذا الكتيب حصرا ل موظفين متخصصين الذي يعرف معايير البناء و أجهزة الحماية ضد الحوادث للوابواب الآلية ، والأبواب والأبواب الرئيسية (اتباع المعايير والقوانين النافذة) .
- 2° - المثبت سوف تضطر إلى إصدار كتيب للمستخدم النهائي وفقا لل 12635 .
- 3° - قبل متابعة التثبيت، يجب المثبت توقع تحليل مخاطر إغلاق automatized النهائية وسلامة النقاط الخطيرة التي تم تحديدها (بعد معايير EN 12453) .
- 4° - قبل تثبيت المحرك الحركة، و يجب التحقق من أن المثبت بوابة المتداول في ظروف ميكانيكية جيدة ، وأنه يفتح ويغلق بشكل كاف .
- 5° - المثبت يجب تثبيت عضو لإطلاق سراح دليل على ارتفاع أقل من 1,8 متر.
- 6° - المثبت سوف تضطر إلى إزالة العرائيل التي قد تعوق الحركة الآلية من بوابة المتداول (مثل مسامير الباب، انزلاق براغي ، وأقفال الأبواب وغيرها)
- 7° - المثبت لديها بشكل دائم لوضع التحذير به ضد انحراف في نقطة مرئية جدا أو بالقرب ضوابط ثابتة ممكن.
- 8° - تسخير الأسلاك من مختلف مكونات الكهربائية الخارجية للمשלح (على سبيل المثال الخلايا الكهروضوئية ، والبطاريات الخ) يجب أن تنفذ وفقا ل EN 60204-1 والتعديلات عليها القيام به في النقطة 5.2.2 من EN 12453 .
- 9° - ويجب أن يتم تجميع ممكن من لوحة المفاتيح للتحكم يدوي للحركة عن طريق وضع لوحة المفاتيح بحيث أن الشخص تشغيله لا يجد نفسه في موقف خطير ؛ وعلاوة على ذلك ، يجب أن تخفض من خطر تفعيل عرضي من الأزرار.
- 10° - الحفاظ على الضوابط تلقائي (لوحة الضغط على زر ، تحكم عن بعد وغيرها) للخروج من الطريق الأطفال. يجب وضع الجهاز الأوامر لتشغيل المحرك (مفتاح مغلق يدويا) في المنطقة المرئية من موقع موجهة وبعيدة عن أجزاء متحركة. وينبغي وضعها على الأقل 1,5 م ارتفاع .
- 11° - هذه الأجهزة يمكن استخدامها من قبل الأطفال الذين تتراوح أعمارهم بين 8 سنوات وما فوق و الأشخاص ذوي القدرات المادية والحسية والعقلية انخفاض أو عدم وجود الخبرة والمعرفة إذا ما أعطيت الإشراف أو تعليمات بشأن استخدام الأجهزة بطريقة آمنة وفهم المخاطر الناجمة عنها
- 12° - الأطفال لا يجوز اللعب مع الأجهزة
- 13° - لا يجوز جعل التنظيف والصيانة المستخدم من قبل الأطفال دون إشراف
- 14° - لا تسمح للأطفال باللعب مع ضوابط ثابتة. الحفاظ على أجهزة التحكم من بعد بعيدا عن تناول الأطفال
- 15° - يجب تثبيت أجهزة القيادة الثابتة بطريقة مرئية أيضا.
- 16° - قبل تنفيذ أي عملية التثبيت ، وتنظيم أو صيانة للنظام، و خلع الجهد من خلال العمل على مغناطيسي خاص التبديل الحراري توصيل المنبع.
- 17° - في نهاية التثبيت، سوف المثبت ديك للتأكد من أن أجزاء من الباب لا رهنها الشوارع أو الأرصفة العامة.

شركة RIB لا تقبل أي مسؤولية عن الأضرار المحتملة الناجمة عن عدم مراعاة أثناء تثبيت معايير السلامة والقوانين المعمول بها في الوقت الحاضر.

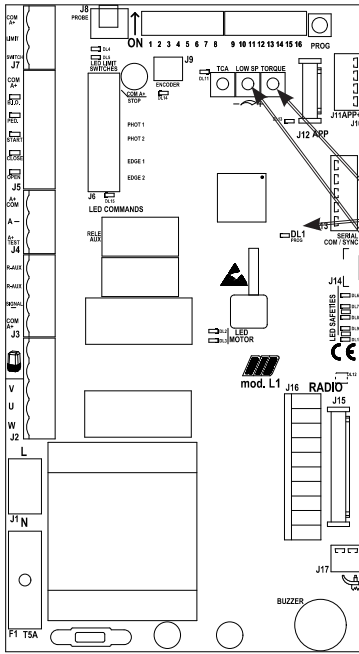

- 3- فحص اتجاه الحركة، ضبط القوة والبطء عند الاقتراب
تعديل القوة وضبط السرعة المنخفضة عند الاقتراب
ملاحظة: في هذه المرحلة، تتحرك البوابة فقط عن طريق الضغط باستمرار على زر PROG وهو نوع خطوة بخطوة مما يعني أنه في كل مرة يتم الضغط على زر PROG لدينا حركة مفتوحة مفتوحة ..
(أ) ضع البوابة في منتصف الطريق.
(ب) ضبط التبديل الجزئي ل OFF و K800 DIP 1-2-3-4-5-6-7-8-13-14-15-16 on ON و DIP 9-10-11-12 on ON.
ل مجموعة K1400 DIP 14 ON
ل مجموعة K2200 DIP 15 ON.
(ج) اضبط DIP 1 على ON (يوميض مصباح DL1 بسرعة)
(د) اضبط أداة ضبط قوة "TORQUE" على الحد الأدنى
(هـ) اضغط مع الاستمرار على زر PROG وقم بزيادة قوة "TORQUE" تدريجياً، فقط عند الضرورة (تحذير: قد يكون استخدام القوة المفرطة خطيراً على المستخدمين)
(ف) بعد 8 ثوانٍ، يتباطأ المحرك في السرعة التي يتم ضبطها باستخدام ماكينة قص الشعر "LOW SPEED".
(ز) حرر زر PROG واضغط على PROG مرة أخرى حتى تبعد البوابة 20 سم عن مفتاح حد الإغلاق.
(ح) اضبط DIP 1 مرة أخرى على OFF.

4 - برمجة الافتتاح الكلي.

- ملاحظة: إذا كانت مدخلات STOP و PHOT 1 و PHOT 2 و EDGE 1 و EDGE 2 غير متصلة، فقم بإجراء وصلات ربط بين / COM A+ / STOP و PHOT 1 / PHOT 2 / EDGE 1 / EDGE 2 قبل متابعة البرمجة.
ملحوظة: في هذه الحالة، سيتم تجاهل أجهزة سلامة أزرار الحافة والضوئية والإيقاف. يجب أن تكون مصابيح DL6-7-8-9-10 في وضع التشغيل.
1 - هام: ضع البوابة على بعد 20 سم تقريباً من تبديل حد الإغلاق.
2 - ضع DIP 2 في الوضع ON <= يبدأ مؤشر DL1 في الوميض.
3 - اضغط على زر PROG./RADIO/OPEN/START. سوف تبدأ البوابة سلسلة من الحركات. لا تمشي أمام الخلايا عندما تتحرك البوابة. اكتمال الإعداد عندما تظل البوابة مغلقة ويغلق مصباح DL1.
4 - تعيين DIP 2 مرة أخرى إلى OFF.

5: برمجة فتح المشي

- يجب أن تكون البوابة مغلقة بالكامل.
1 - ضبط DIP2 أول على ON (يضيء مصباح DL1 بسرعة) وبعد DIP1 إلى ON (يضيء مصباح DL1 ببطء).
2 - اضغط على زر المشاة (M1 => COM A+/PED.) يفتح.
3 - اضغط على زر المشاة (COM A+/PED.) لإيقاف M1 عند النقطة المطلوبة.
4 - اضغط على زر المشاة (COM A+/PED.) لإغلاق M1.
5 - عند الوصول إلى الإغلاق، قم بإعادة ضبط DIP 1 و DIP 2 إلى OFF.

6: برمجة جهاز التحكم عن بعد للفتح الكلي

- يمكن أن تتم البرمجة فقط عندما تكون البوابة ثابتة.
1- قم بتعيين DIP 1 إلى ON أولاً ثم DIP 2 إلى ON. يوميض LED DL12 باللون الأحمر لمدة 10 ثوانٍ.
2 - اضغط على زر التحكم من بعد (عادةً ما تكون القناة A) خلال الثواني العشر المخصصة. إذا تم حفظ جهاز التحكم عن بعد بشكل صحيح يوميض LED DL12 باللون الأخضر وتؤكد نغمة الجرس على الحفظ الصحيح.
يتم تجديد الثواني العشر من برمجة البرمجة تلقائياً، مع إضاءة LED DL12 باللون الأحمر، من أجل تخزين جهاز الإرسال التالي.
3 - لإنهاء البرمجة، انظر 10 ثوانٍ، أو اضغط على الزر PROG باختصار. LED DL12 توقف وامض.
4 - إعادة تعيين DIP 1 إلى OFF و DIP 2 إلى OFF.

7: تخصيص الضبط

- من الممكن تعديل الضبط من خلال تحريك المفاتيح الكهربائية
4 DIP الخلايا الضوئية نشطة دائماً [OFF] - الخلايا الضوئية نشطة فقط أثناء الإغلاق [ON]
5 DIP قبل وامض [ON] - يوميض عادي (إيقاف)
6 DIP أمر النبض الفردي (START) ورايو - خطوة بخطوة [ON] - تلقائي (إيقاف)
7 DIP تنشيط الخلايا الضوئية AUTO-TEST (تشغيل - نشط).
8 DIP إدارة التشفير (ON - تفعيل) لنماذج PLUS - مع التشفير
9 DIP تباطؤ (تشغيل - تمكين)
10 DIP الفرامل الإلكترونية (ON - المنشط)
11 DIP بداية تدريجية (تشغيل - نشط)
12 DIP تنشيط نظام الراديو SUN-PRO [OFF] - SUN [ON]
13 DIP إدارة جهات الاتصال (ON - نشط) - ملاحظة: حتى إذا تم تمكينها، فإن DIPs 8-9-10-11 مستنناة من عملها
ل مجموعة K800 DIP 14-15-16 OFF
ل مجموعة K1400 DIP 15-16 OFF ، DIP 14 ON
ل مجموعة K2200 DIP 14-16 OFF ، DIP 15 ON

هام: يجب أن يتطابق النظام مع كل المعايير والتوجيهات المعمول بها حالياً.

تنبيه: • قم بتثبيت بطاقة APP (أو بطاقة APP+ مع وحداتها) واستخدام هاتفك الذي مع تطبيق RIB GATE App للاستفادة من جميع الوظائف المتقدمة التي يمكن أن يقدمها لك مجلس L1.

SIMPLIFIED INSTRUCTIONS FOR K800-1100-1400-2200 FCE-FCM WITH L1-CRX

1° Connecting the motor and limit switch (done in the factory)



K FCE



K FCM

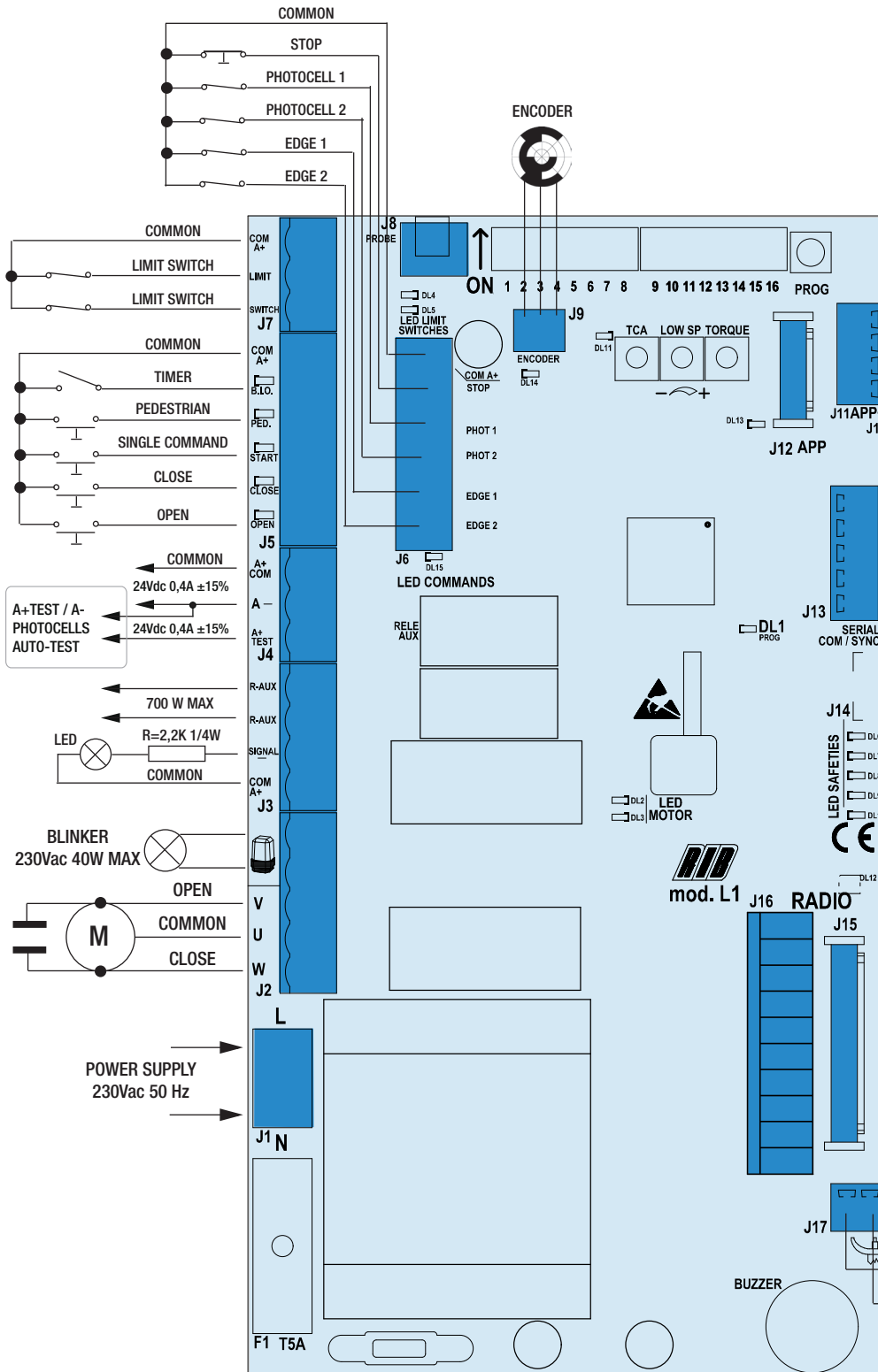

TORQUE TRIMMER - Electronic regulator for motor torque
Adjustment of motor torque is carried out using the TORQUE Trimmer which varies the output voltage to the head/s of the motor/s (turn clockwise to increase torque).

This torque control is activated after 2 s from any manoeuvre begging, whereas the motor is turned on at full power to guarantee the starting at the manoeuvre begging.

PAY ATTENTION: IF THE TORQUE TRIMMER SETTING IS CHANGED, IT IS PREFERABLE TO REPEAT THE TIME PROGRAMMING.

LOW SPEED TRIMMER - Electronic regulator for low speed on approach

Adjustment of low speed is carried out using the LOW SPEED Trimmer which varies the output voltage to the head/s of the motor/s (turn clockwise to increase speed). Adjustment is carried out to establish the correct speed at the completion of opening and closing, depending on the structure of the gate, or if there is any light friction that could compromise the correct working of the system.

TCA TRIMMER - AUTOMATIC CLOSING pause time regulator for TOTAL or PEDESTRIAN openings
default NOT ACTIVATED and LED DL11 OFF (trimmer fully rotated counterclockwise)

This trimmer makes it possible to adjust the pause time for total or pedestrian automatic closing. Only with gate completely open (total) or partially open (pedestrian) and LED DL11 ON (trimmer rotated clockwise to activate the feature).

The pause time (for a totally opened gate) can be adjusted from a minimum of 2 s up to a maximum of 2 minutes.

The pause time (for gate open with PED. control) can be adjusted from a minimum of 2 s to a maximum of 30 s.

2° Installing and adjusting the limit plate cams

Place the cams on the rack.

Tighten the two screws to lock them. How to finely adjust cam intervention is explained below.



Release the motor (turn the key counter K FCE



K FCM

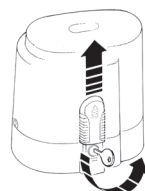

clockwise until the limit is reached without forcing) and move the gate by hand

Check when the cams are activated.

Note: The cams must press the electric microswitches before the mobile part touches the mechanical stops.

3. Force adjustment and low speed adjustment when approaching

Note: In this phase the gate moves only by constantly pressing the PROG button and is the step-by-step type which means that each time the PROG button is pressed we have an open-close-open ... manoeuvre.

- Position the gate halfway.
- Set the microswitches for K800 DIP 1-2-3-4-5-6-7-8-13-14-15-16 on OFF and DIP 9-10-11-12 on ON.
for K1400 set DIP 14 ON
for K2200 set DIP 15 ON.
- Set DIP 1 on ON (the DL1 LED flashes quickly)
- Set the "TORQUE" force adjustment trimmer on minimum
- Press and hold the PROG button and gradually increase "TORQUE" force, only if necessary (WARNING: too much force can be dangerous for the users)
- After 8 s the motor slows to a speed that is adjusted with the "LOW SPEED" trimmer.
- Release the PROG button and press PROG again until the gate is 20 cm from the closing limit switch.
- Put DIP 1 back on OFF.

4. PROGRAMMING TOTAL OPENING.

NOTE: If the STOP, PHOT 1, PHOT 2, EDGE 1 and EDGE 2 inputs are not connected, make jumpers between COM A+ / STOP / PHOT 1 / PHOT 2 / EDGE 1 / EDGE 2 before proceeding with programming.

NB: In this case the Edge, Photocell and Stop button safety devices will be ignored. The LEDs DL6-7-8-9-10 must be on.

- IMPORTANT: POSITION THE GATE AT APPROXIMATELY 20 CM FROM THE CLOSING LIMIT SWITCH.**
- Put the DIP 2 in the ON position => the DL1 LED begins to flash.
- Press the PROG./RADIO/OPEN/START button. The gate will begin a series of movements. DO NOT WALK IN FRONT OF THE PHOTOCELLS WHEN THE GATE IS MOVING. Set up is complete when the gate remains closed and the DL1 LED is OFF.
- Turn the DIP 2 back to the OFF position.

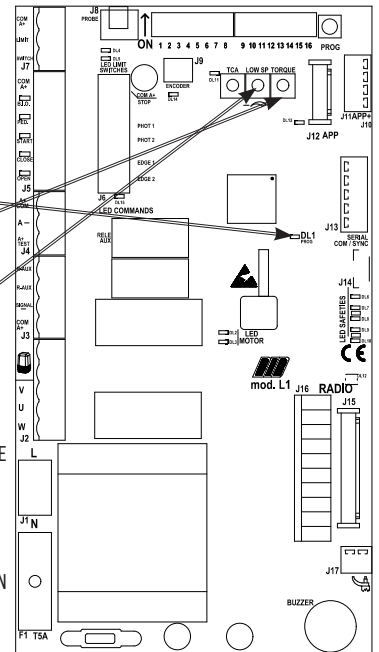

5. PROGRAMMING THE PEDESTRIAN GATEWAY OPENING

With the gate closed:

- First set DIP 2 to ON (DL1 led flashes quickly) and after DIP1 to ON (DL1 led flashes slowly).
- Press the pedestrian button (COM A+/PED.) => M1 opens.
- Press the pedestrian button (COM A+/PED.) To stop M1 at the desired point.
- Press the pedestrian button (COM A+/PED.) To close M1.
- When the closure is reached, reset DIP 1 and 2 to OFF.

6. PROGRAMMING THE REMOTE CONTROL FOR TOTAL OPENING

Programming can be done only when the gate is stationary.

- First set DIP 1 to ON and then DIP 2 to ON. The LED DL12 flashes red for 10 s.
- Press the remote button (usually channel A) within the allotted 10 s. If the remote is memorized properly LED DL12 blinks green and a buzzer tone confirms the correct memorization. The 10 s for programming the codes are automatically renewed, with LED DL12 which flashes red, in order to store the next transmitter.
- To finish programming, wait 10 s, or press the PROG button briefly. LED DL12 stops flashing.
- Re-set DIP 1 to OFF and DIP 2 to OFF.

7. Customising configuration

You can change the configuration by moving the various micro-switches

- DIP 4 Photocells always active (OFF) - Photocells active only during closing (ON)
- DIP 5 Pre-blinking (ON) - Normal blinking (OFF)
- DIP 6 Single pulse command (START) and RADIO - step-by-step (ON) - automatic (OFF)
- DIP 7 Photocells AUTO-TEST activation (ON - activated).
- DIP 8 Encoder management (ON - activated) for SET PLUS ACG-5460 with encoder
- DIP 9 Slowdown (ON - activated)
- DIP 10 Electronic brake (ON - activated)
- DIP 11 Gradual start (ON - activated)
- DIP 12 Activate the radio system SUN (ON) - SUN-PRO (OFF)
- DIP 13 Contactors management (ON - activated) - NOTE: Even if enabled, DIPs 8-9-10-11 are excluded from their operation

for K800 set DIP 14-15-16 OFF

for K1400 set DIP 15-16 OFF, DIP 14 ON

for K2200 set DIP 14-16 OFF, DIP 15 ON.

IMPORTANT: The system must comply with all the standards and Directives currently in force.

ATTENTION: Install the APP card (or the APP+ card with its modules) and use your smartphone with the RIB GATE App to take advantage of all the advanced features that the L1 control board can offer you.

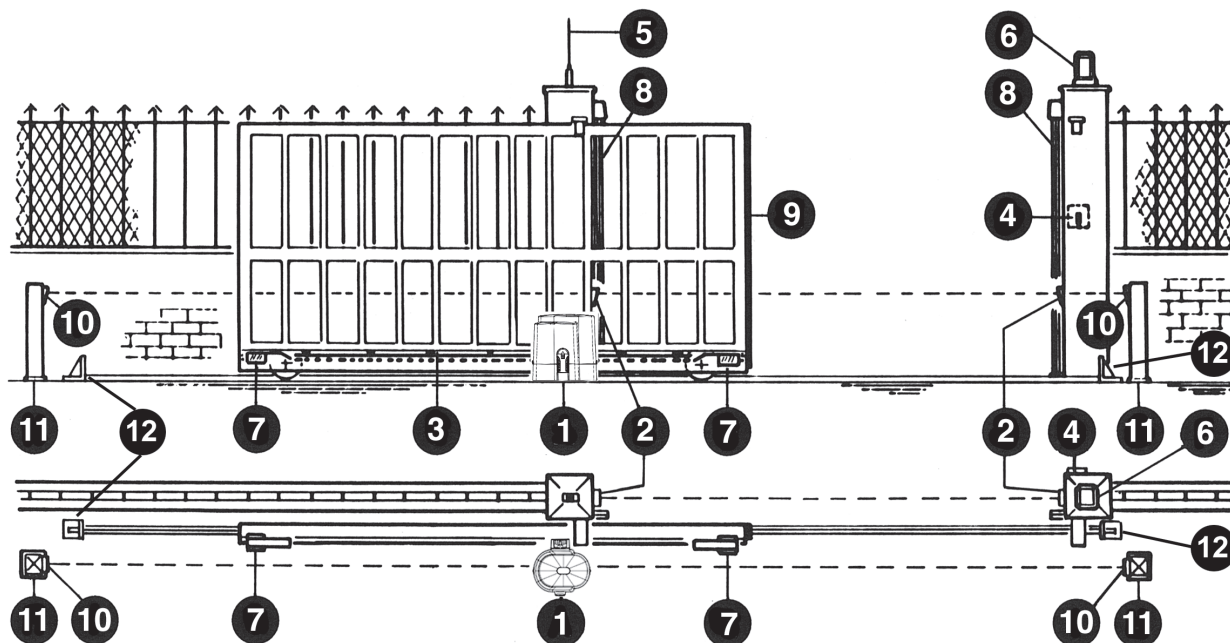

- 1 - K operating device
- 2 - External photocells
- 3 - Rack of Module 4
- 4 - Key selector
- 5 - Radio antenna
- 6 - Blinker
- 7 - Limit switch plate (cams)
- 8 - TOUCH Safety edge or VERTIGO photocell
- 9 - TOUCH Safety edge or VERTIGO photocell
- 10 - Internal Photocells
- 11 - Photocell columns
- 12 - Mechanical stops

TECHNICAL FEATURES

Irreversible operating devices for sliding gates with a maximum weight of 2.200 kg / 4900 lbs.

The irreversibility of this operating device allows you to avoid using any electric lock for an effective closing of the gate. The motor is protected by an heat probe, that temporary interrupts the operating cycle in case of prolonged use.

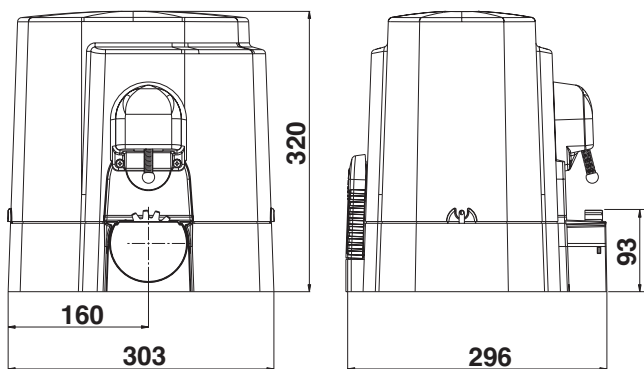

Measurements in mm

1

TECHNICAL DATA		K800	K1100	K1400	K2200
Max. leaf weight	kg	800	1100	1400	2200
Operating speed	m/s	0,155/0,18			
Rack		4			
EEC Power supply		230V~ 50/60Hz			
Thrust force to constant turns	N	600	735	790	1150
Max. torque	Nm	20,4	25	27	39
Motor capacity	W	287/262	361/343	257/314	247/311
Power absorbed	A	1,38/1,19	1,58/1,37	1,18/1,44	1,1/1,62
Capacitor	µF	12,5	16	12,5	16
Power supply		120 V~ 60Hz			
Thrust force to constant turns	N	514	590	737	1175
Max. torque	Nm	17,5	20	25	40
Motor capacity	W	242	355	267	295
Power absorbed	A	2,15	3,22	3	2,85
Capacitor	µF	40	60	50	60
Normative cycles 230V	n°	7 - 38s/2s	6 - 38s/2s	8 - 64s/2s	12 - 64s/2s
Normative cycles 120 V	n°	10 - 38s/2s	11 - 38s/2s	7 - 64s/2s	12 - 64s/2s
Daily operations suggested	n°	300	400	400	500
Service	%	50	50	70	70
Guaranteed consecutive cycles	n°	8/6m	5/6m	15/10m	15/10m
Grease		COMLUBE LHITGREASE EP/GR.2			
Weight of electroreducer	kg	10,5	10,8	12,3	14
Noise	db	<70			
Working temperature	°C	-10 ÷ +55°C			
Protection	IP	44			

CHECKING BEFORE THE INSTALLATION

!! THE GATE SHALL MOVE FRICTIONLESS !!

N.B.: Gate features must be uniformed with the standards and laws in force. The door/gate can be automated only if it is in a good condition and its conditions comply with the BS EN 12604 norm.

- The door/gate leaf does not have a pedestrian door. In the opposite case it is necessary to take the appropriate steps, in accordance with EN 12453 norm (for instance; by preventing the operation of the motor when the pedestrian door is opened, by installing a safety microswitch connected with the control panel).
- Besides the electrical or mechanical limit switches available on the operators, there must be, on both ends of the installation, a fixed mechanical stopper which stop the gate in the unlikely event of ill functioning of limit switches on the operators. For this reason the fixed mechanical stopper must be of an adequate size to withstand the static and kinetic forces generated by the gate [12] [2].
- Gate columns shall have anti-derailment guides on their top [3], to avoid the unintentional gate release.

N.B.: Remove mechanical stops like the one in fig. 3.

No mechanical stops shall be on top of the gate, since these mechanical stops are not safe enough.

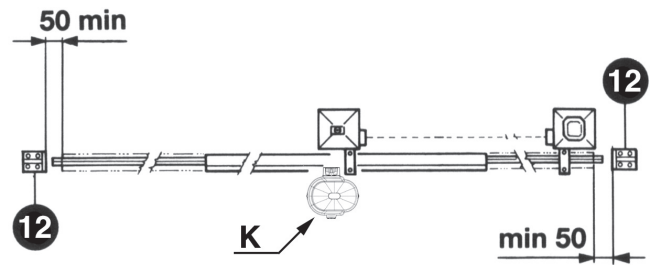

2

Parts to install according to BS EN 12453 standard			
COMMAND TYPE	USE OF THE SHUTTER		
	Skilled persons (out of public area*)	Skilled persons (public area)	Not skilled persons
Hold-to-run operation	A	B	Not possible
Impulsive - in sight (e.g. push-button)	C or E	C or E	C and D, or E
impulsive - out of sight (e.g. remote)	C or E	C and D, or E	C and D, or E
automatic	C and D, or E	C and D, or E	C and D, or E

* a typical example are those doors which do not have access to any public way
 A: Hold-to-run operation made by push-button ex: code ACG2013
 B: Hold-to-run operation made by key selector ex: code ACG1010
 C: Adjustable power of the motor or photocells to respect impact forces as indicated in Annex A
 D: Safety strips and/or other additional devices to reduce the probability of contact with the door.
 E: Devices installed in such a way that a person can not be touched by the door.

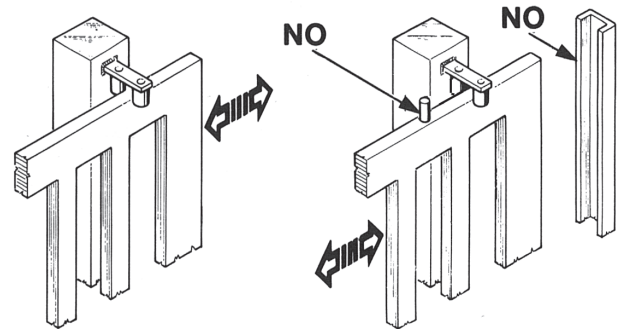

3

RELEASE

To operated after the power supply to the motor has been interrupted.

In order to work manually on the gate, you just need to insert the fitting key and rotate it 4 times counterclockwise [4].

In order to carry out the manual operation of the gate leaf the followings must be checked:

- That the gate is endowed with appropriate handles;
- That these appropriate handles are placed so to avoid safety risks for the operator;
- That the physical effort necessary to move the gate leaf should not be higher than 225 N, for doors/gates for private dwellings, and, 390N for doors/gates for commercial and industrial sites (values indicated in 5.4.5 of the BS EN 12453 norm) .

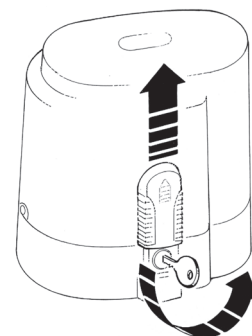

4

MOTOR AND RACK FITTING

The holes for fixing the nylon rack must be made at 123,5 mm height from the motor support (at 130mm for the iron rack).

The height of the rack can be adjusted thanks to the slots available on its right -angled bar.

The height adjusting is necessary to prevent the gate leaning on the driving gear (5 and 6).

To fasten the nylon rack on the gate, drill Ø 5 mm holes on the moving part of the gate and thread them using a M6 tap thread (Ø 7 mm and M8 for iron rack).

The driving gear needs some 1 mm clearance from the rack.

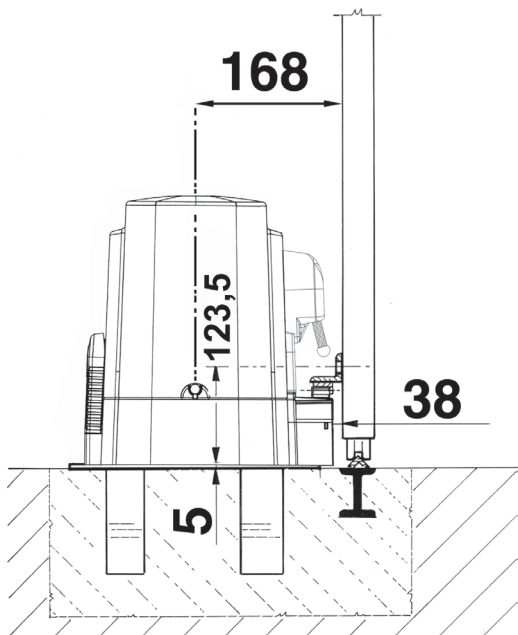

Measurements in mm

5

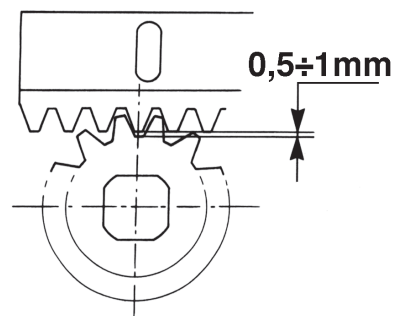
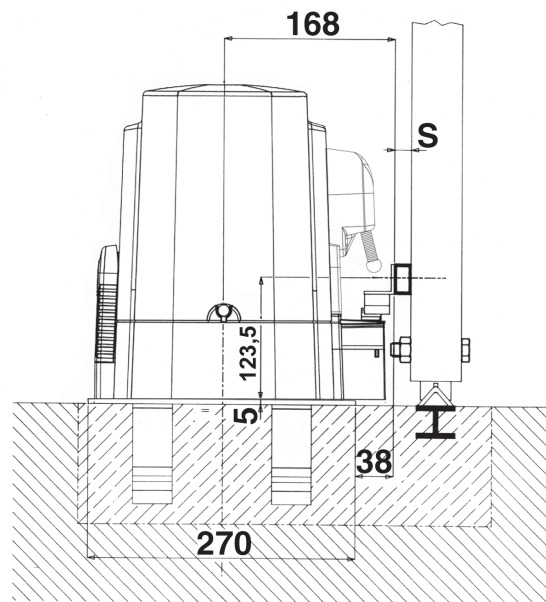

Measurements in mm

6

LIMIT SWITCH FITTING

In order to determine the gate travel length, place two cams at the ends of the rack (7-8).

Move the cams on the rack teeth to adjust their opening and closing travel.

To fix the cams to the rack, tighten the screws issued.

N.B: In addition to the electric stop cams mentioned above, you must also install strong mechanical stops preventing the gate from sliding out from the top guides.

MAINTENANCE

To be carried out exclusively by skilled persons after the power supply to the motor has been interrupted.

Periodically, when the gate is standstill, clean and keep the guide free from stones and dirt.



7

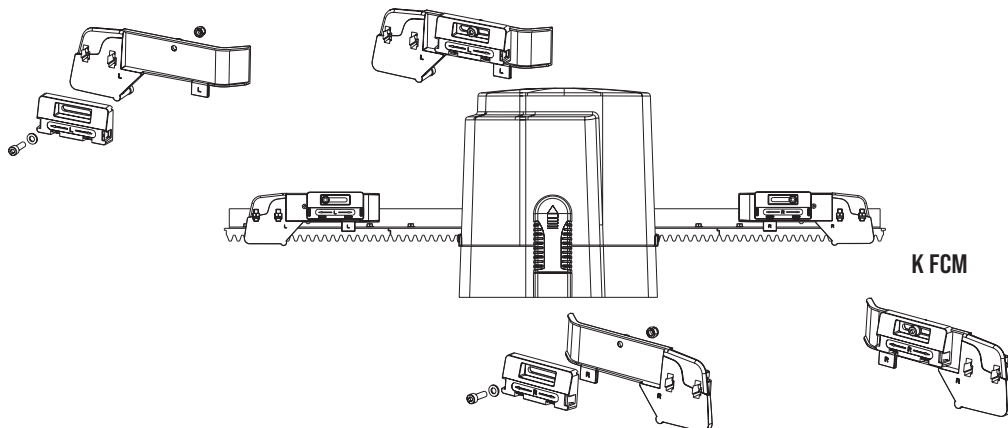

K FCM

8

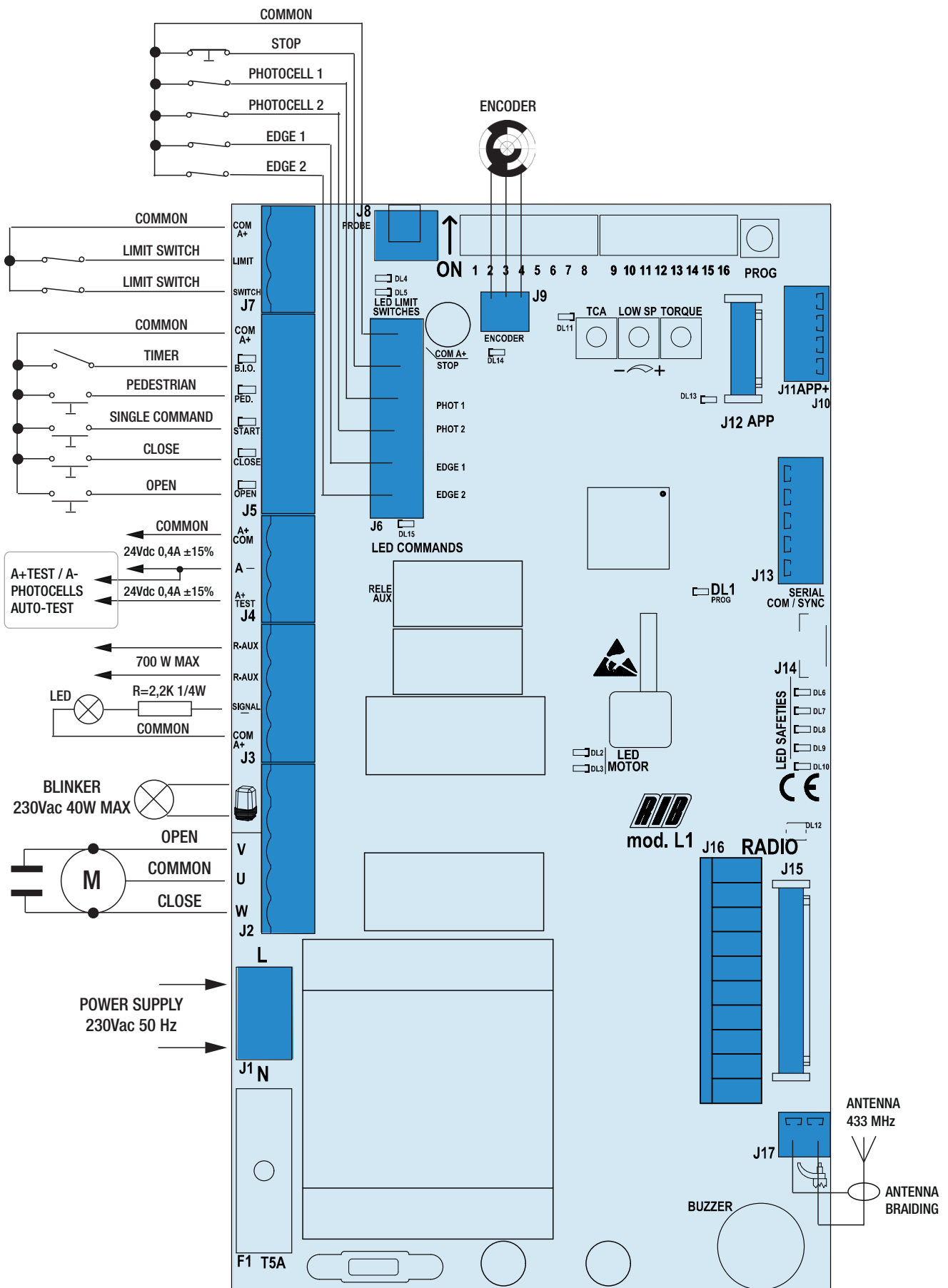



Manuali online interattivi
 Manuels interactifs en ligne
 Interactive online manuals
 Interaktive Online-Handbücher
 Manuales interactivos en línea.

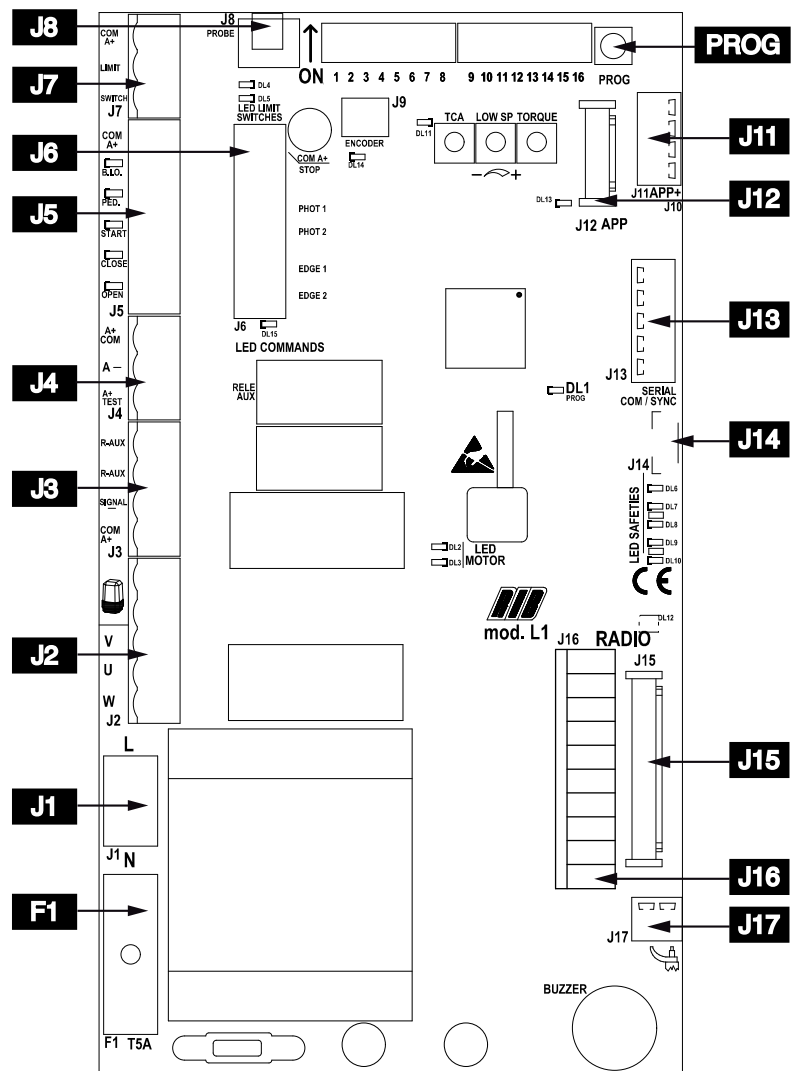

J1	L1 - N	230 Vac 50/60Hz power supply (120 Vac 60Hz upon request)	J7	COM A+	Common contacts / Positive 24 Vdc
J2		Flashing light (max 40 W)		LIMIT SWITCH	Limit switches that cuts OFF the motor
	U	Motor common connection	J8	PROBE	Temperature sensor cable connection probe (code ACG4665 optional)
	V-W	Motor phases and capacitor connections	J9	ENCODER	Encoder connection (SET PLUS code ACG5460)
J3	R-AUX	Auxiliary relay contact (NO) Max 700 W	J10		RS485 termination of J11
	SIGNAL	Gate open state [24 Vdc 3 W max]	J11	APP+	Connector for APP+ card
	COM A+	Common contacts / Positive 24 Vdc	J12	APP	Connector for APP card
J4	A+ COM	+ 24 Vdc accessories power supply	J13	SERIAL COM / SYNC	Connector for serial connection
	A-	- 24 Vdc accessories power supply	J14	-	-
	A+ TEST	+ 24 Vdc photocells self-test power supply	J15	RADIO	Connector for radio module ACG8069
J5	COM A+	Common contacts / Positive 24 Vdc	J16	RADIO	Connector for radio receiver RIB, 24 Vdc supply
	B.I.O.	Contact (NO) dedicated to a clock	J17		433 MHz Radio antenna
	PED.	Pedestrian opening contact (NO)	PROG.		Programming button
	START	Single pulse contact (NO)	TCA		Trimmer for automatic closing time adjustment (DISABLED DEFAULT AND DL11 LED OFF)
	CLOSE	Closing impulse contact (NO)	LOW SP		Electronic regulator for low speed on approach
J6	OPEN	Opening impulse contact (NO)	TORQUE		Electronic torque regulator
	COM A+	Common contacts / Positive 24 Vdc	F1	T5A	Fuse for motor protection
	STOP	STOP impulse contact (NC)			
	PHOT 1	Photocells contact 1 (NC)			
	PHOT 2	Photocells contact 2 (NC)			
	EDGE 1	Edge 1 contact (NC)			
	EDGE 2	Edge 2 contact (NC)			

POINT B - SETTINGS

DIP 1	MAINTENANCE CHECK (See Page 15)
DIP 2	TIMES PROGRAMMING (See Point C)
DIP 2-1	PROGRAMMING OF PEDESTRIAN OPENING (See Point D)
DIP 1-2	SAVE/DELETE RADIO CODES FOR COMPLETE OPENING (DIP 1 ON followed by DIP 2 ON) (POINT E)
DIP 1-3	SAVE/DELETE RADIO CODES FOR PEDESTRIAN OPENING (DIP 1 ON followed by DIP 3 ON) (POINT F)
DIP 1-2-3	SAVE/DELETE RADIO CODES FOR RELAY R-AUX COMMAND (point G)
DIP 3	(ON) - REMOTE PROGRAMMING OF REMOTE CONTROLS DEACTIVATED
DIP SWITCHES CONTROL	
DIP 4	Photocells always active (OFF) - Photocells active only during closing (ON)
DIP 5	Pre-blinking (ON) - Normal blinking (OFF)
DIP 6	Single pulse command (START) and RADIO - step-by-step (ON) - automatic (OFF)
DIP 7	Photocells AUTO-TEST activation (ON-activated).
DIP 8	Encoder management (ON - activated) for SET PLUS ACG5460- with encoder
DIP 9	Slowdown (ON - activated)
DIP 10	Electronic brake (ON-activated)
DIP 11	Gradual start (ON-activated)
DIP 12	Activate the radio system SUN (ON) - SUN-PRO (OFF)
DIP 13	Contactors management (ON - activated) - NOTE: Even if enabled, DIPs 8-9-10-11 are excluded from their operation

DIP 14	DIP 15	DIP 16	MOTOR TYPE
OFF	OFF	OFF	K800 - K1100
ON	OFF	OFF	K1400
OFF	ON	OFF	K2200

TORQUE TRIMMER - Electronic regulator for motor torque

Adjustment of motor torque is carried out using the TORQUE Trimmer which varies the output voltage to the head/s of the motor/s (turn clockwise to increase torque).

This torque control is activated after 2 s from any manoeuvre begging, whereas the motor is turned on at full power to guarantee the starting at the manoeuvre begging.

PAY ATTENTION: IF THE TORQUE TRIMMER SETTING IS CHANGED, IT IS PREFERABLE TO REPEAT THE TIME PROGRAMMING.

LOW SPEED TRIMMER - Electronic regulator for low speed on approach

Adjustment of low speed is carried out using the LOW SPEED Trimmer which varies the output voltage to the head/s of the motor/s (turn clockwise to increase speed). Adjustment is carried out to establish the correct speed at the completion of opening and closing, depending on the structure of the gate, or if there is any light friction that could compromise the correct working of the system.

TCA TRIMMER - AUTOMATIC CLOSING pause time regulator for TOTAL or PEDESTRIAN openings by factory NOT ACTIVATED and LED DL11 OFF (trimmer fully rotated counterclockwise)

This trimmer makes it possible to adjust the pause time for total or pedestrian automatic closing. Only with gate completely open (total) or partially open (pedestrian) and LED DL11 ON (trimmer rotated clockwise to activate the feature).

The pause time (for a totally opened gate) can be adjusted from a minimum of 2 s up to a maximum of 2 minutes.

The pause time (for gate open with PED. control) can be adjusted from a minimum of 2 s to a maximum of 30 seconds.

Ex: With TCA trimmer setted halfway, you will have 1 minute pause after the total opening and 15 s of pause after the pedestrian opening prior to have the auto-close of the gate.

R-AUX - AUXILIARY RELAY CONTACT (NO)

By default this relay is set as courtesy light (max 700 W - 3 A - 230 Vac) to operate 3 minutes at each command, with time renewed at each command.

You can activate the R-AUX contact by TRANSMITTER by performing the memorization procedure described in point G.

ELECTRONIC BRAKE

DIP 10 ON => the electronic brake will activate upon total opening or closing.

N.B.: ELECTRONIC BRAKE for FAST operators is always enabled

If DIP10 is turned ON, a HARD electronic brake will be active.

If DIP10 is turned OFF, a SOFT electronic brake will be active.

GRADUAL START

DIP 11 ON => a gradual movement will be enabled for 1second upon each starting.

In case of an obstacle is detected by any safety inputs (photocell, safety strip or encoder), the gradual start is bypassed for the time being to guarantee a more prompt and safe reaction.

LED WARNINGS

DL1	PROG programming activated	(red)
DL2	Gate opening	(green)
DL3	Gate closing	(red)
DL4	Opening limit switch LSO	(green)
DL5	Closing limit switch LSC	(red)
DL6	STOP command (NC)	(red)
DL7	PHOTO 1 contact (NC)	(red)
DL8	PHOTO 2 contact (NC)	(red)
DL9	EDGE 1 contact (NC)	(red)
DL10	EDGE 2 contact (NC)	(red)
DL11	TCA - automatic closure time enabled	(red)
DL12	Remotes programming enabled	(red/green)
DL13	L1 managed by APP	(blue)
DL14	Encoder enabled	(red)
DL15	PROG and RADIO (on MOLEX connector) commands	(green)
B.I.O	Clock command (NO)	(green)
PED.	Pedestrian command (NO)	(green)
START	Single impulse command (NO)	(green)
CLOSE	CLOSE command (NO)	(green)
OPEN	OPEN command (NO)	(green)

PROBE

It's a cable ended with a sensor to detect the motor temperature and, if necessary, to active automatically the motor warning (code ACG4665).

POINT C - TIMES PROGRAMMING

N.B. : During the programming the safety functions Coast, Photocells, Stop button and Impact detection are active and their performance level is pl "b" according to EN13849-1. their intervention stops the programming (the led DL1 from flashing remains lit steadily).

N.B. : If the STOP, PHOT 1, PHOT 2, EDGE 1 and EDGE 2 inputs are not connected, make jumpers between COM A+/STOP/PHOT 1/PHOT 2/EDGE 1/EDGE 2 before proceeding with programming. **N.B. :** In this case the safety Edge, Photocells and Stop button will be ignored.

N.B. : The start slow-down point is automatically determined in the time programming phase and 50 ÷ 60 cm is activated before reaching the opening or closing limit switch.

N.B.: TO REPEAT THE PROGRAMMING REPOSITION THE GATE TO 20 CM FROM THE CLOSING LIMIT SWITCH AND FOLLOW THE PROCEDURES BELOW.

- PROGRAMMING WITHOUT ENCODER (DEDICATED TO ENGINES K800 - K1400 - K2200 - SUPER 2200 - SUPER 3600 - SUPER 4000 - SUPER 6000 - SUPER 8000 FAST) **N.B. :** THE DIP 8 MUST BE ON OFF !!

- PROGRAMMING WITH ENCODER (DEDICATED TO ENGINES K800 - K1400 - K2200 with SET PLUS ACG5460) **N.B. :** THE DIP 8 MUST BE ON ON !!

1 - **N.B. :** POSITION THE GATE TO ABOUT 20 CM FROM THE CLOSING LIMIT SWITCH.

2 - Set DIP 2 to ON => LED DL1 will flash briefly.

3 - Press the PROG or START or OPEN button or the button of the remote control dedicated to the total opening (if previously programmed). The gate will start a series of movements. **DO NOT PASS IN FRONT OF THE PHOTOCELLS WHILE THE GATE IS MOVING.** The programming ends when the gate is closed and the DL1 LED is OFF.

4 - **AT THE END OF PROGRAMMING, RESET THE DIP 2 ON OFF.**

N.B. : If you program without encoder (DIP 8 OFF) and then install the encoder (DIP 8 ON) you must repeat the programming

D - PROGRAMMING OF PEDESTRIAN OPENING TIMES

With closed gate and closing limit switch engaged (mandatory).

1 - **First set DIP 2 to ON** (LED DL1 flashes quickly) and **after DIP1 to ON** (LED DL1 flashes slowly).

2 - Press the PED pedestrian button. or the remote control button dedicated to the pedestrian opening (if previously programmed) => The gate opens.

3 - Press the pedestrian button **PED.** to stop the run (thus defining the opening of the gate).

4 - Press the pedestrian button to start closing.

5 - **When the closing limit switch is reached, reset DIP1 and 2 to OFF.**

During programming, the safety devices are active and their intervention stops the programming (the LED from blinking remains lit steadily and the buzzer sounds for 10 s).

To repeat the programming position the **DIP 1 and DIP 2 to OFF**, close the gate and repeat the procedure described above.

E - RADIO CODES PROGRAMMING PROCEDURE FOR TOTAL OPENING (1000 CODES MAX) - with radio module ACG8069

ATTENTION: before storing the radio codes, use DIP 12 to select which transmitters to use:

- DIP 12 OFF:** SUN-PRO variable code transmitters can be memorized:
 SUN-PRO 2CH 2-channel - red keys and white led cod. ACG6210
 SUN-PRO 4CH 4-channel - red keys and white led cod. ACG6214

DIP 12 ON (by factory): You can store transmitters with fixed code SUN:

- SUN 2CH 2-channel - blue keys and white led cod. ACG6052
 SUN 4CH 4-channel - blue keys and white led cod. ACG6054
 SUN CLONE 2CH 2-channel - blue keys and yellow led cod. ACG6056
 SUN CLONE 4CH 4-channel - blue keys and yellow led cod. ACG6058

ATTENTION: it is not possible to memorize at the same time transmitters with fixed code and transmitters with variable code.

Programming can be done only when the gate is stationary.

- 1 - First set **DIP 1 to ON** and then **DIP 2 to ON**. The LED DL12 flashes red for 10 s.
- 2 - Press the TRANSMITTER button (usually channel A) within the allotted 10 s. If the remote is memorized properly LED DL12 blinks green and a buzzer tone confirms the correct memorization. The 10 s for programming the codes are automatically renewed, with LED DL12 which flashes red, in order to store the next transmitter.
- 3 - To finish programming, wait 10 s, or press the PROG button briefly. LED DL12 stops flashing.
- 4 - Re-set **DIP 1 to OFF** and **DIP 2 to OFF**.

REMOTE PROGRAMMING NEW REMOTE CONTROLS DEDICATED TO TOTAL OPENING

- 1 - Press the button on the valid remote control dedicated to fully opening the gate 3 times in rapid succession. The buzzer will sound once for 1 second and the flasher will flash for 4 seconds to signal the activation of the procedure.
 - 2 - Immediately then press the same button once on the new remote control(s) you want to register. The buzzer will sound 1 time to confirm the registration of each new remote control. Wait 4 seconds for the procedure to exit. The flasher will turn off.
- If you do not want to use this function, set DIP 3 to ON to deactivate it.

ALL RADIO CODES FOR TOTAL OPENING CANCELLATION PROCEDURE

Cancellations can only be performed when gate is stationary.

- 1 - Set **DIP 1 to ON** and then **DIP 2 to ON**.
- 2 - LED DL12 flashes red for 10 s.
- 3 - Press and hold the PROG button for 5 s. Memory cancellation is indicated by two green flashes of LED DL12 and 2 tones of the buzzer.
- 4 - LED DL12 flashes red again for 10 seconds and you can add new codes as shown above.
- 5 - Re-set **DIP 1 to OFF** and **DIP 2 to OFF**.

RADIO CODES MEMORY FULL INDICATOR (FOR TOTAL OPENING)

Indication is visible only when gate is stationary.

- 1 - Set **DIP 1 to ON** and then **DIP 2 to ON**.
- 2 - The LED DL12 flashes green 6 times when the memory is full (1000 codes). Now LED DL12 blinks red for 10 s enabling possible cancellation of all codes.
- 3 - Re-set **DIP 1 to OFF** and **DIP 2 to OFF**.

F - RADIO CODES PROGRAMMING PROCEDURE FOR PEDESTRIAN OPENING**(1000 CODES MAX) - with radio module ACG8069**

Programming can be done only when the gate is stationary.

- 1 - Set **DIP 1 to ON** and then **DIP 3 to ON**. DL12 flashes green for 10 s.
- 2 - Press the transmitter button (usually channel B) within the allotted 10 s. If the transmitter is properly memorized LED DL12 blinks red and the buzzer emits a tone. The 10 s are automatically renewed (DL12 flashes green) in order to memorize next transmitter.
- 3 - To finish programming wait 10 s, or press the PROG button briefly. The LED DL12 stops flashing.
- 4 - Reset **DIP 1 to OFF** and **DIP 3 to OFF**.

REMOTE PROGRAMMING NEW REMOTE CONTROLS DEDICATED TO PEDESTRIAN OPENING

- 1 - Press the button on the valid remote control dedicated to pedestrian opening of the gate 3 times in rapid succession. The buzzer will sound 2 times for 1 second and the flasher will flash for 4 seconds to signal the activation of the procedure.
 - 2 - Immediately then press the same button once on the new remote control(s) you want to register. The buzzer will sound 1 time to confirm the registration of each new remote control. Wait 4 seconds for the procedure to exit. The flasher will turn off.
- If you do not want to use this function, set DIP 3 to ON to deactivate it.

ALL RADIO CODES FOR PEDESTRIAN OPENING CANCELLATION PROCEDURE

Cancellation can only be performed when the gate is stationary.

- 1 - Set **DIP 1 to ON** and then **DIP 3 to ON**. LED DL12 flashes green for 10 s.

- 2 - Press and hold the PROG button for 5 s. Memory cancellation is indicated by two red flashes of LED DL12 and two tones of the buzzer.
- 3 - The red LED DL1 remains active and you can add new codes as shown above.
- 4 - Reset **DIP 1 to OFF** and **DIP 3 to OFF**.

RADIO CODES MEMORY FULL INDICATOR (FOR PEDESTRIAN OPENING)

Indication is visible only when gate is stationary.

- 1 - Set **DIP 1 to ON** and then **DIP 3 to ON**.
- 2 - LED DL12 flashes green 6 times if the memory is full (1000 codes). LED DL12 blinks red for 10 s enabling possible cancellation of codes.
- 3 - Set **DIP 1 to OFF** and **DIP 3 to OFF**.

G - PROGRAMMING RADIO CODES FOR R-AUX RELAY (1000 CODES MAX) - with radio module ACG8069

Programming can be done only when the gate is stationary.

- 1 - Set **DIP 1 to ON**, **DIP 2 to ON** and then **DIP 3 to ON**. DL12 flashes orange for 10 s.
- 2 - Press the transmitter button (usually channel C) within the allotted 10 s. If the transmitter is properly memorized LED DL12 blinks green and the buzzer emits a tone. The 10 s are automatically renewed (DL12 flashes orange) in order to memorize next transmitter.
- 3 - To finish programming wait 10 s, or press the PROG button briefly. The LED DL12 stops flashing.
- 4 - Reset **DIP 1, 2, 3 to OFF**.

REMOTE PROGRAMMING NEW REMOTE CONTROLS DEDICATED TO THE R-AUX RELAY

- 1 - Press the button on the valid remote control dedicated to pedestrian opening of the gate 3 times in rapid succession. The buzzer will sound 3 times for 1 second and the flasher will flash for 4 seconds to signal the activation of the procedure.
 - 2 - Immediately then press the same button once on the new remote control(s) you want to register. The buzzer will sound 1 time to confirm the registration of each new remote control. Wait 4 seconds for the procedure to exit. The flasher will turn off.
- If you do not want to use this function, set DIP 3 to ON to deactivate it.

RADIO CODES CANCELLATION PROCEDURE (FOR R-AUX RELAY)

Cancellation can only be performed when the gate is stationary.

- 1 - Set **DIP 1 to ON**, **DIP 2 to ON** and then **DIP 3 to ON**. LED DL12 flashes green for 10 s.
- 2 - During these 10 s press and hold the PROG button for 5 s. Memory cancellation is indicated by two green flashes of LED DL12 and two tones of the buzzer.
- 3 - LED DL12 blinks orange again for 10 s and you can add new codes as shown above.
- 4 - Re-Set **DIP 1, 2, 3 to OFF**.

RADIO CODES MEMORY FULL INDICATOR (FOR R-AUX RELAY)

Indication is visible only when gate is stationary.

- 1 - Set **DIP 1 to ON**, **DIP 2 to ON** and then **DIP 3 to ON**.
- 2 - LED DL12 flashes green 6 times if the memory is full (1000 codes). LED DL12 blinks red for 10 s enabling possible cancellation of codes.
- 3 - Re-Set **DIP 1, 2, 3 to OFF**.

FUNCTIONING OF CONTROL ACCESSORIES**STEP-BY-STEP BUTTON (COM A+/START)**

DIP 6 ON => It cyclically performs the commands open-stop-close-stop-open etc.

DIP 6 OFF => Opens the gate when closed. There is no effect if activated while opening. If activated when gate is open, the gate closes. If activated while closing, the gate re-opens.

OPEN BUTTON (COM A+/OPEN)

The button controls the opening movement when the gate is stationary. If activated while closing, it re-opens the gate.

B.I.O. BUTTON - OPENS WITH CLOCK FEATURE (COM A+/B.I.O.)

This function is useful during peak hours, when vehicle traffic is slow (e.g. entry/exit of workers, emergencies in parking or residential areas and, temporarily, for moving operations). By connecting a switch and/or a daily/weekly clock to COM A+/B.I.O., you can open and keep the automation open for as long as the switch is pressed or the clock remains active. When the gate is open, all the commands are ignored.

Releasing the switch or at the end of the set time, the automation closes immediately.

Note: By activating the B.I.O. command for a time lower than the opening time (gate that has not yet finished opening), even with an impulse, at the end of opening the gate will close again after the automatic closing waiting time (fw 07.00 or higher).

CLOSE BUTTON (COM A+/CLOSE)

Controls the closing movement when the gate is stationary.

TRANSMITTER

DIP 6 ON => It cyclically performs the commands open-stop-close-stop-open etc.

DIP 6 OFF => Opens the gate when closed. There is no effect if activated while opening. If activated when gate is open, the gate closes. If activated while closing, the gate reopens.

PEDESTRIAN OPEN BUTTON (COM A+/PED.)

Partial opening and closing control.

During pedestrian opening, pausing or closing, you can control the opening of any command linked to the L1 board.

With **DIP 6** you can choose the operation mode of the pedestrian push button.

DIP 6 ON => It cyclically performs the commands open-stop-close-stop-open etc.

DIP 6 OFF => Opens the gate when closed. There is no effect if activated while opening. If activated when gate is open, the gate closes. If activated while closing, the gate reopens.

FUNCTIONING OF SAFETY ACCESSORIES**SAFETY ENCODER (SET PLUS ACG5460)**

The Encoder acts as a safety device both during gate closing and opening by reversing the motor movement in case of impact detection.

The functioning of the motor with encoder is enabled by **DIP 8** (ON - activated).

If the Encoder is faulty (lack of power, disconnected cables, broken or defective disk), the gate will not move.

After the Encoder intervenes in opening or closing, the gate stops and then reverses for 1 second, entering alarm.

Note: The DL14 LED signals flashing that the encoder is operating correctly during gate movement.

ENCODER ALARM - impact detection

The alarm status is signaled by the flasher which will be active for 1 minute, and by the BUZZER with 5 tones every 5 s for 1 minute.

During or after the 1 minute alarm, the gate can start again by pressing any command button.

PHOTOCELLS (COM A+/PHOT 1, COM A+/PHOT 2)

NOTE: the transit through the photocells is signaled by a buzzer tone

DIP 4 OFF => if an obstacle is placed in range of the photocells when the gate is closed, the gate does not open. During operation, photocells work when opening (by starting the opening movement only after the obstacle is removed) and closing (by starting the reverse movement only after the obstacle is removed).

DIP 4 ON => if an obstacle is placed in range of the photocells when the gate is closed and the command to open is given, the gate opens (the photocells do not work while opening). Photocells work only during closing (with reverse motion restored after a second, even if they are still engaged).

ATTENTION: In case the receiver led remains lit, malfunctioning of the main supply is suspected.

It is advisable to connect electrically to earth the columns or the photocells stands to the terminal A -, to shield the photocells from external noise.

Be careful not to short circuit the system when the supply phases are inverted!

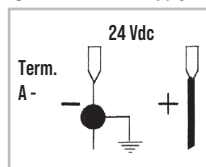
**PHOTOCELLS MONITORING (A+ TEST A-) as required by EN12453 par. 5.1.2**

Connect the photocells to A+ TEST/A- and set DIP 7 to ON.

The monitoring consists of a functional test of the photocell run before every movement.

The gate movement is therefore permitted only if the photocells have passed the functional test.

CAUTION: MONITORING OF THE PHOTOCELLS INPUTS (PHOTO 1/PHOTO 2) CAN BE ACTIVATED WITH DIP 7 ON OR DEACTIVATED WITH DIP 7 OFF.

WARNING: If the AUTOTEST feature is enabled and only one photocell is connected, a jumper must be made between the PHOT 1 and PHOT 2 terminals. If the jumper is not made, the AUTOTEST fails and the gate will not move.

PHOTOCELL AUTOTEST ALARM (DIP 7 ON)

If the photocell fails the monitoring test, an alarm is displayed by the blinker lighting up and gate movement is not allowed. Normal operation can be restored only by repairing the photocell and pressing one of the controls.

EDGES (SAFETY STRIPS) (COM A+/EDGE 1, COM A+/EDGE 2)

If engaged when closing, EDGE 1 reverses the motion in opening. If edge remains engaged, it doesn't permit the closing.

If engaged during opening, EDGE 2 reverses the motion in closing. If edge remains engaged, it doesn't permit the opening.

If edges are not used, jump the terminals COM A+/EDGE1/EDGE2.

EDGE ALARM

Flasher and buzzer are activated with 2 tones every 5 s for one minute.

EDGE MONITORING (as required by EN12453 par. 5.1.2)

Using the APP card and the RIB GATE App, it is possible to enable monitoring of mechanical edges (NC with 8K2 resistance) and resistive edges (NO with 8K2 resistance).

STOP BUTTON (COM A+/STOP)

The STOP button stops the gate during any operation.

If held when the gate is fully open (or partially when using the pedestrian control) automatic closing is temporarily deactivated (if activated by the TCA trimmer and LED DL11 on). It is therefore necessary to use a new command to make it close.

The automatic closing function is reactivated on the next cycle (if activated by the TCA trimmer and LED DL11 ON).

FUNCTIONING IN HOLD-TO-RUN MODE WHEN THE SAFETY DEVICES ARE FAILING

If one of the safety edges fails or remains engaged for more than 5 s, or if one of the photocells fails or remain engaged for more than 60 seconds, the OPEN, CLOSE, START and PED. commands will work only in hold-to-run mode.

The signal that this mode has been activated is given by the blinking of the programming led DL1.

The radio commands and the automatic closing will be excluded, since their use in this mode is not allowed by the norms.

Once the failing safety device is repaired, in automatic after 1 second, all standard commands functioning again so radio commands and the automatic closing will be enabled again.

Note 1: during this functioning in hold-to-run mode, in case of damage to the safety strips (or photocells) the photocells (or safety strips) still work by interrupting the operation in progress.

Note 2: the stop command is not to be considered a safety command that can be bypassed in this mode. Therefore, when pressed or damaged, it will not allow any movement of the gate.

The hold-to-run mode is only an emergency operation which must be activated for a very short period and with the complete installation at sight so to have a secure and safe control of the system. As soon as possible however, the failing safety devices must be repaired and activated.

VISUAL AND SOUND ALARMS**BLINKER**

Connect the flashing light to the blinker output, use flashing lights ACG7072 and bulbs of 40W maximum.

PRE-BLINKING

DIP 5 OFF => motor and blinker start simultaneously.

DIP 5 ON => blinker starts 3 seconds before the motor.

BUZZER

It has the task to signal the intervention of the security, the anomalies and the memorization and cancellation of the radio codes.

SIGNAL - 24Vdc GATE OPEN WARNING LIGHT (COM A+/SIGNAL-)

Signals when the gate is open, partially open or not closed completely. It turns OFF only when the gate is completely closed.

During opening, it flashes slowly.

When the gate is stationary or opened, it is permanently on.

During closing, it flashes quickly

N.B.: Max 3 W. If warning lights are in excess, the control panel processes will be endangered with possible stop of all operations.

OPERATION AFTER BLACK-OUT

At the time of the blackout, gate status is saved in the memory.

When mains voltage is restored:

If the gate is located on the opening or closing limit switch, operating the control will close or

open the gate with the saved data.

If the gate is in intermediate position, operating the control will open the gate slowly until it reaches the opening limit switch. After completing this first movement, the operator will resume work at the set speed.

TECHNICAL SPECIFICATIONS

- Humidity	< 95% without condensation
- Power voltage	230V~ ±10% (120V/60Hz upon request)
- Frequency	50/60Hz
- Maximum board absorption	30mA
- Interruptions in electricity supply	100ms
- Maximum load of open gate output	3 W (equal to 13W bulb or to 5 LEDs connected in series through a resistor of from 2.2 Kohm)
- Blinking unit maximum output load	40W with resistive load
- Current available for photocells and accessories	400mA 24Vdc
- Current available on radio connector	200mA 24Vdc
- ALL THE PUSH BUTTONS, INPUTS AND COMMANDS CONNECTED TO THE CONTROL BOARD MUST BE CLEAN CONTACT.	

TECHNICAL RADIO SPECIFICATIONS (Only L1-CRX)

- Reception frequency	433,92MHz
- Impedance	52 Ω
- Sensitivity	>2.24µV
- Excitation time	300ms
- De-excitation time	300ms
- Codes in store	N° 1000 total

- All the inputs must be used as clean contacts because the power supply is generated internally (safe voltage) in the card and it is set in a way to guarantee the use of the double insulation and reinforced in relation to parts with hazardous voltage.
- Any external circuits connected to the outputs of the control board, must be carried out to make sure the double or reinforced insulation is used in relation to parts with hazardous voltage.
- All the inputs are run by a programmed integrated circuit which carries out a self-check at the beginning of each operation.

MAINTENANCE CHECK

N.B.: During this check the safety functions Edges, Photocells, Stop button and Impact detection are NOT active.

- 1 - Set **DIP 1 to ON** => LED DL1 starts to flash.
- 2 - Press and hold the PROG button (the command is hold-to-run, open-stop-close-stop-open-etc ...) => The gate starts at high speed and then slow down until the limit switch is reached.
- 3 - At the end, put **DIP 1 back to OFF**. The DL1 LED turn OFF signaling the exit from the check.

If the motor does not work during this check, check the connections and its capacitor.
If the motor is working properly, check the safety devices.

TROUBLE SHOOTING

Update the firmware of the panel using the APP card and the RIB GATE app.
After having carried out all connections, by carefully following the layout and having positioned the gate in intermediate position, check the correct ignition of red LEDES DL6, DL7, DL8, DL9 and DL10.

In case of no ignition of the LEDES, always with gate in intermediate position, check the following and replace any faulty components.

DL6	OFF	Stop button malfunction (if Stop is not connected, perform the jump between COM A+ and STOP).
DL7 or DL8	OFF	Faulty photocells (In case the edge is not connected, carry out jumper between COM A+ and PHOTO 1/PHOTO 2)
DL9 or DL10	OFF	Faulty safety edge (In case the edge is not connected, carry out jumper between COM A+ and EDGE 1/EDGE 2)
DL12	OFF	the radio module is working correctly.
	ON	the radio module is missing or faulty or not recognized after a power surge.
DL13 blue	ON	Some functions are enabled via smartphone, so via smartphone check the card functions as the dips/trimmers status may not be true.

On the board there are self-resetting fuses which intervene in the event of a short circuit, interrupting the output assigned to them.

In the event of troubleshooting, it is advisable to disconnect all the removable connectors and insert them one at a time in order to more easily identify the cause of the fault.

FAULT	SOLUTION
After having carried out the various connections and having supplied voltage, all the LEDES are switched OFF.	On the board there are self-resetting fuses which intervene in the event of a short circuit, interrupting the output assigned to them. In the event of troubleshooting, it is advisable to disconnect all the removable connectors and insert them one at a time in order to more easily identify the cause of the fault. Check the integrity of fuse F1. In case of interrupted fuse use only of adequate value F1 = T 5A Fuse for motor protection
The motor opens and closes, but it has no strength and moves slowly.	Check trimmers TORQUE and LOW-SPEED adjustment.
The gate opens but does not close after the time set.	Make sure that the TCA trimmer is activated with LED DL11 ON. B.I.O. contact always on / green led on => check the status of the clock connected to B.I.O. input. Photocells Auto-test failed => check the connections between the control panel and the photocells.
The gate does not open or close by activating the various START, RADIO, OPEN and CLOSE buttons.	Faulty safety edge contact. Faulty photocells contact with DIP 4 to OFF . => Fix or replace the faulty contact. Photocells Auto-test failed => check the connections between the control panel and the photocells.
Motor with encoder (DIP 8 to ON) enabled. The gate opens and closes only for brief intervals.	Check encoder connection and eventually replace.
By activating the START, OPEN or CLOSE button the gate does not move.	START, OPEN or CLOSE command always active. Check and replace any buttons or micro-switches of the selector switch.
The slowing phase is not performed.	Ensure that DIP 9 is ON (Slowdown enabled). Perform the programming times procedure with DIP 2 . Check LOW SPEED trimmer adjustment.

TABLE SUMMARISING VISUAL AND SOUND ALARMS SIGNALS DURING PROGRAMMING SEQUENCE

EVENT	BUZZER STATUS	FLASHER STATUS	DL1 LED STATUS
DIP 1 ON (hold-to-run mode) Or failure of a safety device	OFF	OFF	Flashes ON/OFF 250 ms
DIP 2 ON (full stroke programming)	OFF	OFF	Flashes ON/OFF 500 ms
DIP 2 ON > DIP 1 ON (pedestrian stroke programming)	OFF	OFF	Flashes ON/OFF 500 ms
Programming sequence stopped due to intervention of a safety device	10 s tone with 2 s pause	OFF	On steady
EVENT	BUZZER STATUS	FLASHER STATUS	DL12 LED STATUS
No transmitter code entered	OFF	OFF	Flashes red/green
DIP 1 ON > DIP 2 ON - transmitter code programming for full opening	OFF	OFF	Flashes red for 10 s
DIP 1 ON > DIP 3 ON - transmitter code programming for pedestrian opening	OFF	OFF	Flashes green for 10 s
DIP 1 ON > DIP 2 ON > DIP 3 ON - transmitter code programming for R-AUX relay	OFF	OFF	Flashes orange for 10 s
Correct transmitter codes programming for full opening and R-AUX relay	1 Tone	OFF	Turns green once
Correct transmitter codes programming for pedestrian opening	1 Tone	OFF	Turns red once
Remote control code not present in memory	OFF	OFF	Turns red once
Memory saturated by remote control codes (1000 codes saved)	OFF	OFF	Runs 6 green flashes
Radio code deletion for full opening, pedestrian opening, R-AUX relay	2 Tones	OFF	Runs 2 green flashes
WARNING SIGNALS DURING OPERATION			
EVENT	BUZZER STATUS	FLASHER STATUS	LED STATUS AND SIGNAL OUTPUT
Stop button pressed	OFF	OFF	Led DL6 turns OFF
Photocell intervention	1 Tone	OFF	Led DL7-8 turns OFF
Edge intervention	2 Tones	OFF	Led DL9-10 turns OFF
Failure of a safety device or safety device engaged for too long	OFF	OFF	Led DL1 flashes ON/OFF 250 ms
Alarm from edge	2 Tones every 5 s for 1 minute (It is renewed by giving a command)	Flashes for 1 minute	No led combined
Failed photocells auto-test alarm	4 Tones every 5 s for 1 minute (It is renewed by giving a command)	OFF	No led combined
Alarm from Encoder	5 Tones every 5 s for 1 minute (It is renewed by giving a command)	Flashes for 1 minute	DL14 led is OFF
Functional block activated by smartphone	OFF	OFF	Led DL12 is steady on green.
Achievement of set cycles	6 Tones every 5 s (It is renewed by giving a command)	OFF	No leds matched
Energy saving activated by smartphone	OFF	OFF	Blue led flashes once every 5 s
Alarm from Self-learning failed	Continuous tone for 10 s with 2-s pause. Not active when DIP 2 su OFF	OFF	No leds matched

FINAL OPERATION - The gasket shall be fitted only at the end of the installation, before you mount the case.



Fit the gasket



The gasket is fitted

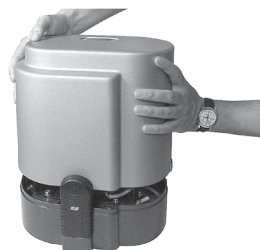

Close the case



Motor ready

ACCESSORIES - For the connections and the technical data of the optional equipments follow the relevant handbooks.

PLATE TO BE CEMENTED

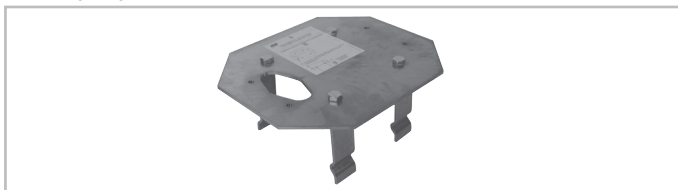

code ACG8107

S18



S18 to embed (NO+NO) code ACG1054
S18 to wall (NO+NO) code ACG1056

S18 to embed (NO+NC) code ACG1054S
S18 to wall (NO+NC) code ACG1056S

SAIL

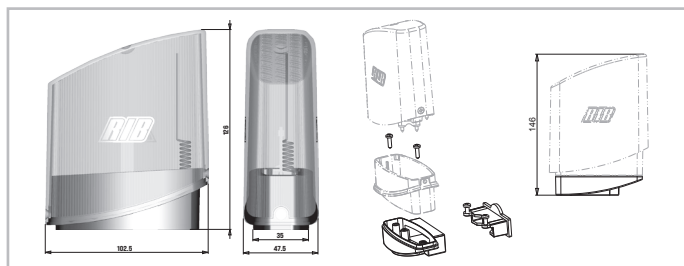

SAIL orange with built-in flashing board
SAIL white with built-in flashing board
SAIL LATERAL SUPPORT

code ACG7072
code ACG7078
code ACG8054

NYLON RACK MODULE 4

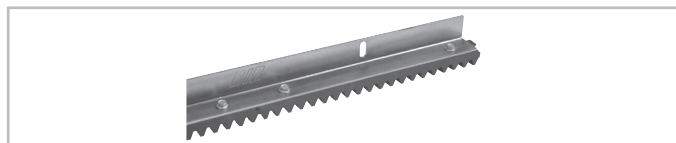

with zinc plated angle Iron, in 1mt. bars. Ideal for gates up to 1,000 kg / 2,200 lbs weight.
1 m / 3,28" code ACS9000
10 m / 32,8" (1 m / 3,28" x 10) code ACS9001

RACK MODULE 4



with zinc plated angle Iron, in 2 m bars.
Ideal for gates up to 1,000 kg / 2,200 lbs weight.

code ACS9050

FIT SYNCRO EN12978 - EN13849-2



FIT SYNCRO PHOTOCELLS for the wall-installation
The range you can set is 10-20 m, 30+60ft.
You can fit many couples close together thanks to the synchronising circuit.
Add the **SYNCRO TRANSMITTER**
for more than 2 photocells couples (up to 4).
COUPLE OF BUILT-IN BOXES FOR THE FIT SYNCRO
PAIR OF COLUMNS FOR FIT SYNCRO H = 0,5 m

code ACG8026B

code ACG8028

code ACG8051

code ACG8057

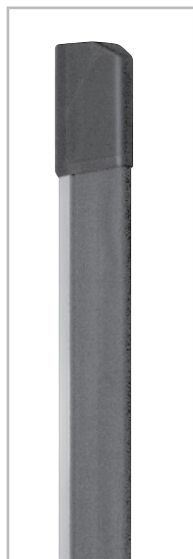

TOUCH

MECHANICAL SAFETY STRIP L = 2 m
CERTIFIED EN 12978 - EN 13849-1:2016 PL "b" CAT.3
code ACG3015

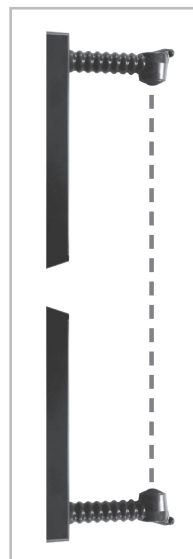

VERTIGO

PHOTOCELLS SUBSTITUTING THE SAFETY STRIP
CERTIFIED EN 12978 - EN 13849-1 PL "c" CAT 2

VERTIGO 8 cod. ACG8044
VERTIGO 10 cod. ACG8045

Applicable vertically and horizontally to sliding and swing gates.

RADIO TRANSMITTER SUN



- | | | | |
|---------------|--------------|---------------|--------------|
| SUN 2CH | cod. ACG6052 | SUN 4CH | cod. ACG6054 |
| SUN CLONE 2CH | cod. ACG6056 | SUN CLONE 4CH | cod. ACG6058 |
| SUN-PRO 2CH | cod. ACG6210 | SUN-PRO 4CH | cod. ACG6214 |

RADIO MODULE 433MHz

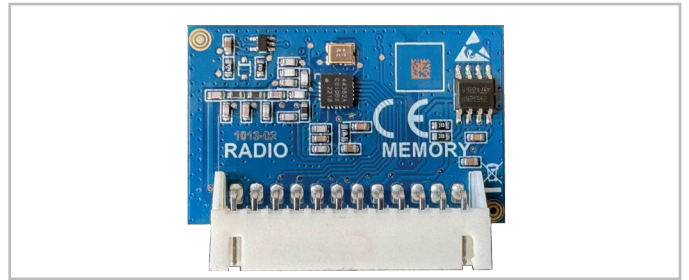

code ACG8069

PROBE



The probe detects the motor temperature to operate the heating system under low temperature conditions, up to -30°C (connect to connector J8). code ACG4665



AC65460 SET PLUS
Encoder to detect obstacles during opening and closing operations.

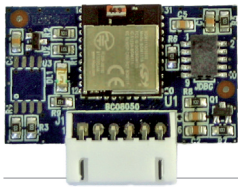

APP8050 APP card
to manage the control panel using Bluetooth 4.2 transmission



APP8054 APP+ card
to manage the control panel using Bluetooth 4.2 transmission

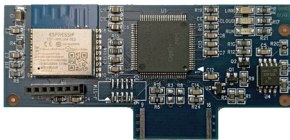

APP8064 Wi-Fi module for APP+ card
to manage the control panel using the local Wi-Fi network (WLAN)

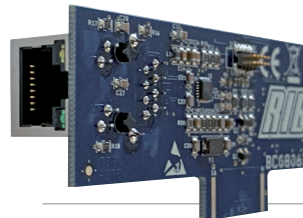

APP8066 RJ45 module for APP+ card
to manage the control panel using the local network (LAN)



APP8060 Clock module for APP+ card
to add access control features to the control panel



PHOTOCELLS CONNECTIONS

2 photocells FIT SLIM, FIT SYNCRO with self-test

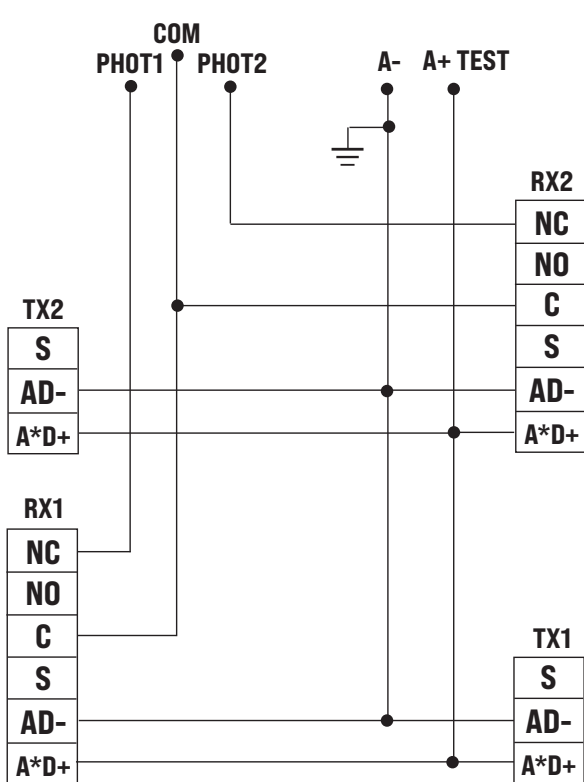

4 FIT SLIM / FIT SYNCRO photocells with self-test and infrared signal synchronizer

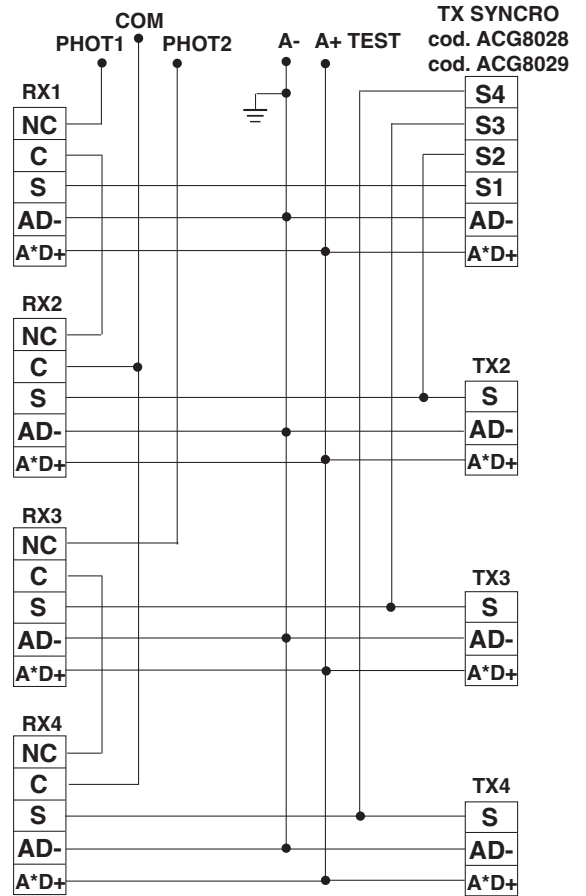

2 photocells F97P, F97I with self-test

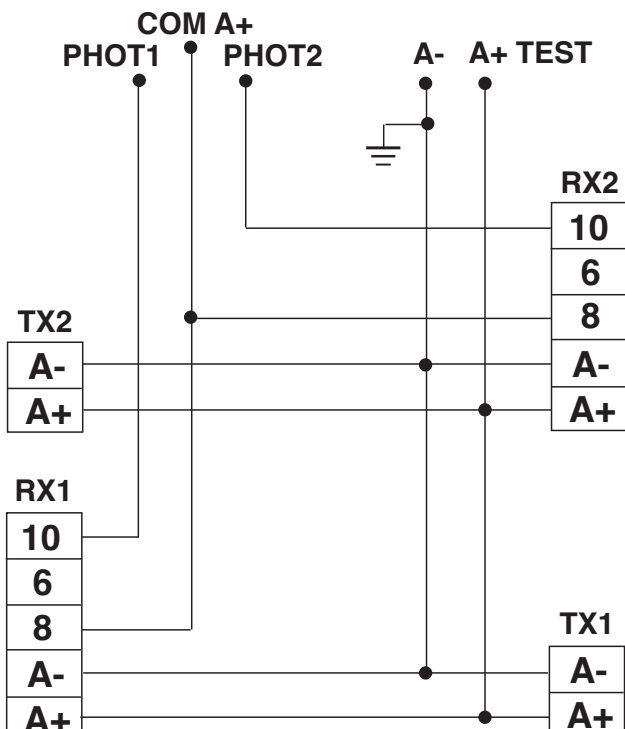

2 photocells FIT METAL with self-test

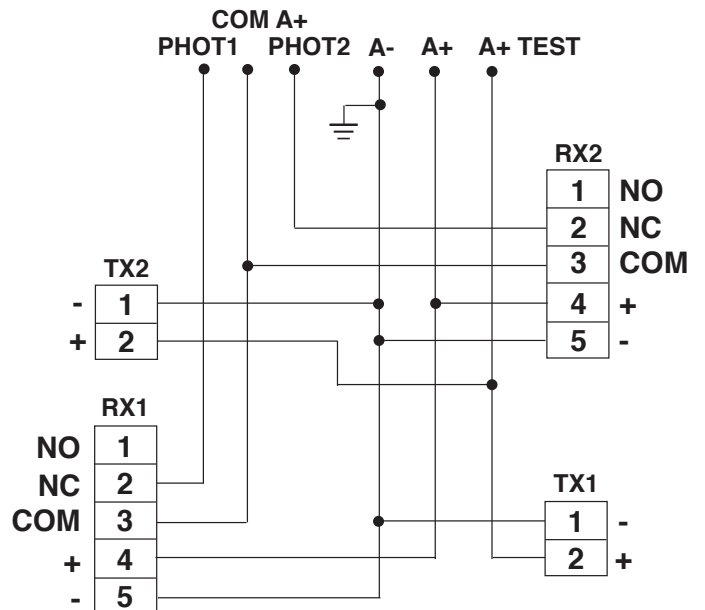

PHOTOCELLS CONNECTIONS

4 NOVA photocells synchronized with self-test

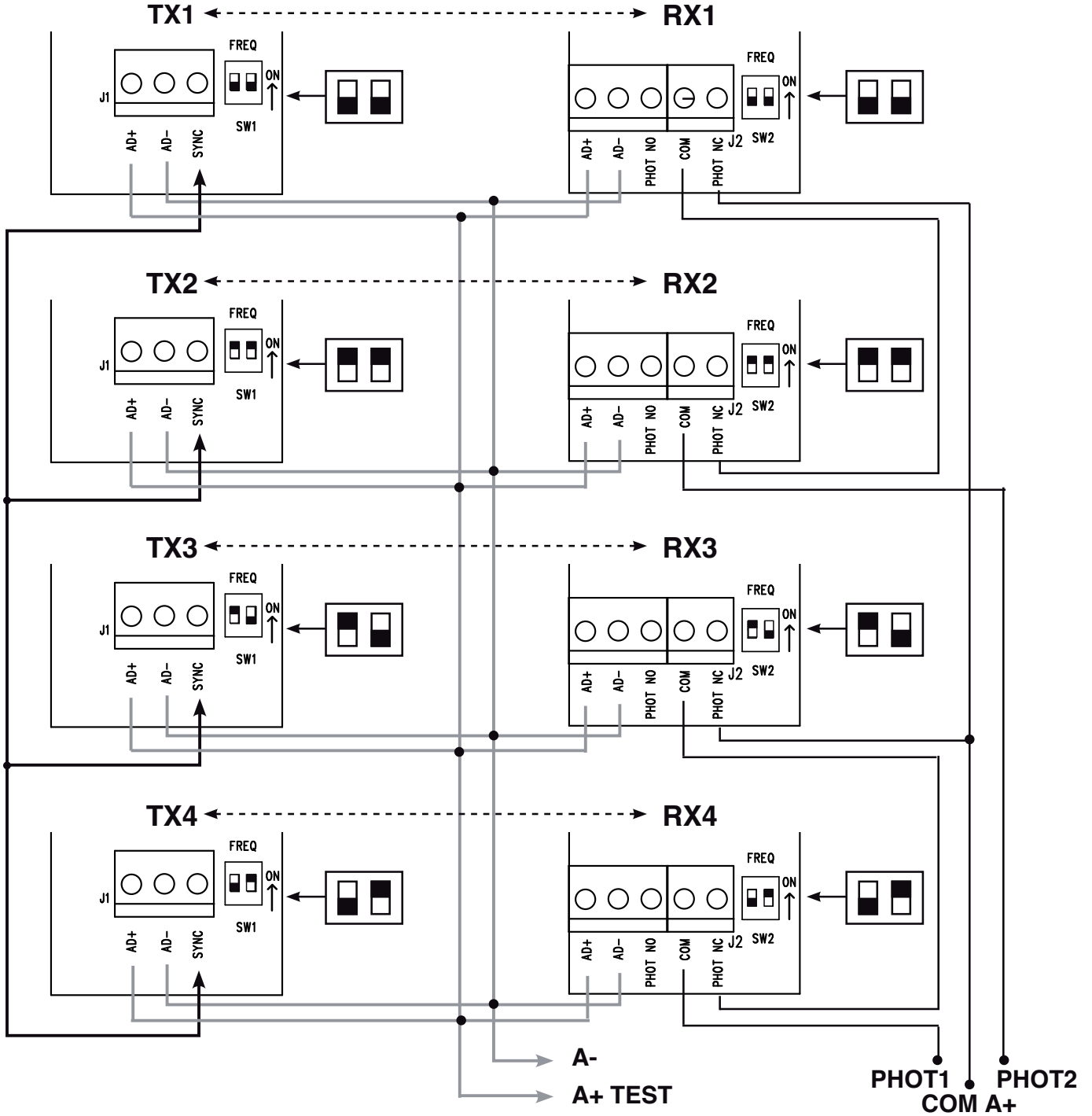

تحذير: في حالة تمكين ميزة AUTOTEST وتوصيل خلية ضوئية واحدة فقط ، يجب إنشاء وصلة ربط بين مطاري PHOT 1 و PHOT 2 . إذا لم يتم إنشاء العبور ، يفشل AUTOTEST ولن تتحرك البوابة.

WARNING: If the AUTOTEST feature is enabled and only one photocell is connected, a jumper must be made between the PHOT 1 and PHOT 2 terminals. If the jumper is not made,

the AUTOTEST fails and the gate will not move.

K800 - K1400 - K2200 FCE-FCM

Codice	Denominazione Particolare
AC08082	Scheda L1
ACG1082	Chiave di sblocco K
ACG5460	Gruppo encoder K
ACG8069	Modulo radio
ACG8672	Serratura esagonale
BA01019	Serie accessori per cilindro
BA01079	Cilindro serratura
BA03230B	Gruppo finecorsa K FCE
BA03230M	Gruppo finecorsa magnetico per K FCM
BA03247M	Gruppo camme per K FCM
BA03350M	Finecorsa magnetico con camme per K FCM
BA03600	Gruppo albero c/corona alluminio K800
BA03610	Gruppo albero c/corona bronzo K1400/2200
BA10072	Ingranaggio di traino
BA10078	Confezione fermi finecorsa verticale
BA10079	Conf. fermi finec. vertical
BA10088	Carter K completo
BA10089	Finecorsa con camme per K FCE
CAL1120	Corona elicoidale per K800
CAL1125	Base scorrevole con semiguscio
CCM6204ZZ	Cuscinetto motore
CEL1378	Cond. 60µF 420/470V per K1400/2200 120/60V
CEL1380	Cond. 12,5µF 450V per K800/1400 230/50V
CEL1382	Cond 16µF 450V per K2200 230/50V
CEL1387	Cond. 40µF 450V per K800 120/60V
CEL1519	Passacavo IP55 GW50431 AC50
CME2025	Vite senza fine per K2200
CME2026	Albero traino
CME2028	Perno di sblocco
CME2043	Corona K1400 - K2200
CME2046	Vite rullata K800 - K1400
CM01188	Motore K1400 230V - 50/60Hz
CM01189	Motore K1400 120 V - 60Hz
CM01297	Motore K2200 230V - 50/60Hz
CM01299	Motore K2200 120 V - 60Hz
CM02602	Motore K800 230V - 50/60Hz
CM02601	Motore K800 120 V - 60Hz
CPL1177	Guida porta micro
CPL1178	Tappo ingranaggio traino
CPL1224	Supporto scheda
CTC1012	Chiavetta 8x7x20
CTC1018	Chiavetta 8x7x50
CTC1164	Spina elastica 6x30
CTC1205	Molla sblocco
CTC1221	Spina cilindrica 10x80
CTC1243	Guarnizione base K
CTC1259	Molla trazione coperchio
CTC1308	Anello di tenuta OR 4100
CTC1355	Anelli di rasamento 25x35x0,5
CTC1406	Paraolio 10x26x7
CVA1372	Boccole flangia 25X32X40X5X2

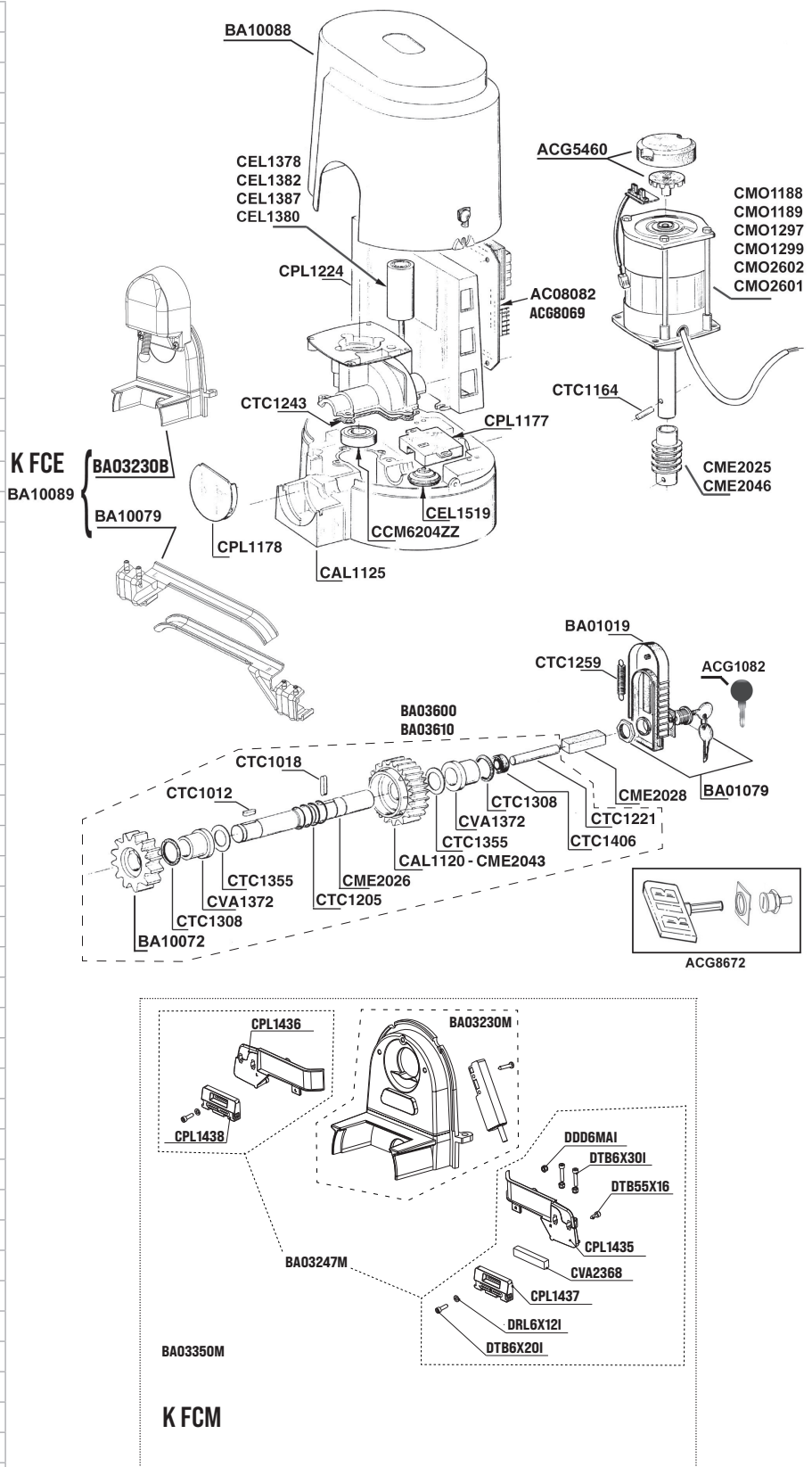

NOTES

WEEE - معلومات للمستخدمين 
في حالة ظهور رمز سلة المهملات المتقاطعة على الجهاز أو العبوة ، فهذا يعني أن المنتج يجب ألا يتم تضمينه مع النفايات العامة الأخرى في نهاية فترة عمله. يجب أن يأخذ المستخدم المنتج البالي إلى مركز فرز تم فرزه ، أو يعيده إلى بائع التجزئة عند شراء منتج جديد. يمكن شحن منتجات التخلص مجاناً (بدون أي التزام جديد بالشراء) إلى تجار التجزئة الذين لديهم مساحة مبيعات لا تقل عن 400 متر مربع ، إذا كانوا يقيسون أقل من 25 سم. يساعد جمع النفايات المصنف بكفاءة للتخلص الملائم للبيئة من الجهاز المستخدم ، أو إعادة تدويره اللاحق ، على تجنب الآثار السلبية المحتملة على البيئة وصحة الناس ، ويشجع على إعادة استخدام و / أو إعادة تدوير مواد البناء.
يجب التخلص من المواد وفقاً للأنظمة المعمول بها. لا تتخلص من المعدات المهملة أو البطاريات المستعملة مع النفايات المنزلية. أنت مسؤول عن أخذ جميع أجهزتك الكهربائية والإلكترونية إلى مركز إعادة تدوير مناسب.

ENGLISH
WEEE - Information for users
 If the crossed-out bin symbol appears on the equipment or packaging, this means the product must not be included with other general waste at the end of its working life. The user must take the worn product to a sorted waste center, or return it to the retailer when purchasing a new one. Products for disposal can be consigned free of charge (without any new purchase obligation) to retailers with a sales area of at least 400 m², if they measure less than 25 cm. An efficient sorted waste collection for the environmentally friendly disposal of the used device, or its subsequent recycling, helps avoid the potential negative effects on the environment and people's health, and encourages the re-use and/or recycling of the construction materials.
Materials must be disposed of in accordance with the regulations in force. Do not throw away your discarded equipment or used batteries with household waste. You are responsible for taking all your waste electrical and electronic equipment to a suitable recycling centre.

إقرار التضمين للماكينة شبه المكتملة - توجيه الماكينات EC/2006/42، الملحق الثاني، "ب"
Declaration of incorporation for partly completed machinery - Machinery Directive 2006/42/EC, Annex II., B

R.I.B. S.r.l. - Via Matteotti, 162 - 25014 Castenedolo - Brescia - Italy
Tel. ++39.030.2135811 - www.ribind.it - ribind@ribind.it

موديل الجهاز: Apparatus model :	K800 - K1100 K1400 - K2200 w/L1-CRX	الغرض من الإقرار: Object of the declaration :		
------------------------------------	--	--	---	--

تم تطبيق المتطلبات الأساسية التالية لتوجيه الماكينات (EC/2006/42) والالتزام بها:
· ألفت الوثائق التقنية ذات الصلة طبقاً للباب "ب" من الملحق السابع؛ إن مثل هذه الوثائق، أو أجزاءها، سوف تُرسل بالبريد أو بوسائل إلكتروني استجابة للطلب المقدم والمستلم من السلطات الوطنية المعنية.

· هذه ماكينة مكتملة تقريبا، وهي مطابقة لبند وأحكام التوجيهات الأوروبية الأخرى: التوجيهان EU/2014/30 و EU/2014/35
· طبقت جميع المتطلبات الأساسية ذات الصلة كما هي واردة في الملحق الأول من التوجيه الأوروبي EC/2006/42 على المنتج. يوفر الامتثال للمعايير المتسقة المذكورة افتراضا للمطابقة مع المتطلبات الأساسية المحددة طبقا للتوجيه الذي تغطيه هذه المعايير أو تمثل أجزاءً منه.
⚠ تحذير: قد تُطبق متطلبات أخرى أو توجيهات أوروبية أخرى على المنتجات التي تندرج تحت نطاق هذا الإقرار.

The following essential requirements of the Machinery Directive (2006/42/EC) and UK Supply of Machinery (Safety) Regulations 2008 are abided by and applied:

- The relevant technical documentation is compiled in accordance with Part B of Annex VII; such documentation, or parts of it, will be sent by post or by electronic means, in response to a motivated request received from the qualified national authorities.
- This almost complete-machinery is conformed with the provisions of these others EC directives: Directives 2014/30/UE, 2014/35/UE and 2014/53/UE and UK Electromagnetic Compatibility Regulations 2016, Electrical Equipment (Safety) Regulations 2016, Radio Equipment Regulations 2017
- All relevant essential requirements as given in Annex I of the EU Directive 2006/42/EC have been applied to the product. Compliance with the cited harmonized standards provides presumption of conformity with the specified essential requirements of the Directive covered by those Standards or parts thereof.
- ⚠ Other requirements and other EU/UK Directives may be applicable to the products falling within the scope of this Declaration

إن الغرض من الإقرار المذكور أعلاه يتوافق مع تشريع الاتساق المعني والخاص بالاتحاد:

The object of the declaration described above is in conformity with the relevant Union harmonisation legislation:

BS EN 12453:2022	BS EN 13849-2:2013	BS EN 55014-1:2023	BS EN 61000-3-2/A2:2024	BS EN 61000-6-4:2022
BS EN 12635:2009	ETSI EN 300 220-1 v3.1.1:2017	BS EN 55014-2:2024	BS EN 61000-3-3/A2:2024	
BS EN 12978:2025	ETSI EN 300 220-3-1 v2.1.1:2016	BS EN 60335-1/A16:2024	BS EN 61000-6-1:2019	
BS EN 13241:2016	BS EN 301 489-1 V2.2.3:2019	BS EN 60335-2-103:2023	BS EN 61000-6-2:2019	
BS EN 13849-1:2023 PL-CAT2	BS EN 301 489-3 V2.3.2:2023	BS EN 60529:1992+A2:2013	BS EN 61000-6-3:2023	

النتج السابق ذكره لا يمكن أن يعمل بصورة مستقلة و إنما هو للتركيب في شبكة مكونة من عناصر اخرى، الرجوع للمادة 6 فقرة 2 من لوائح 2006/42/الوحدة الأوروبية (آلات) و تعديلاتها اللاحقة ، و من

اجلة نعلن منع وضعة في الخدمة قبل أن يتم إعلان مطابقة الشبكة التي سيعمل فيها لمواد اللائحة

- This product can not work alone and was designed to be fitted into a system made up of various other elements. Hence, it falls within Article 6, Paragraph 2 of the EC-Directive 2006/42 (Machines) and following modifications, to which respect we point out the ban on its putting into service before being found compliant with what is provided by the Directive.



[Bosio Stefano - Legal Representative - الممثل القانوني]

Castenedolo, 01-03-2025

CE UK CA
صنع في إيطاليا
MADE IN ITALY



AUTOMATISMI PER CANCELLI
AUTOMATIC ENTRY SYSTEMS

COMPANY WITH
QUALITY SYSTEM
CERTIFIED BY DNV
ISO 9001

تم تطوير هذا المنتج بالكامل وبنائه في إيطاليا
· This product has been completely developed and built in Italy